

## Features

- Gain Bandwidth : 500kHz
- Rail-To-Rail Input And Output
- 0.8mV Typical Vos
- Input Voltage Range : -0.1V to +5.6V with  
Vs = 5.5V
- Supply Range : +2.5V to +5.5V
- Shutdown : CBM8221S/CBM8222S
- Specified Up To +125°C
- Micro Size Packages : SOT23-5, SOT23-6

## Application

- Sensors
- Photo diode Amplification
- Active Filters
- Test Equipment
- Driving A/D Converters

## Description

The CBM8221, CBM8222, CBM8224, CBM8221S, CBM8222S families of products offer low voltage operation and rail-to-rail input and output, as well as excellent speed/power consumption ratio, providing an excellent bandwidth (500kHz) and slew rate of 0.18V/us. The op-amps are unity gain stable and feature an ultra-low input bias current.

The devices are ideal for sensor interfaces, active filters and portable applications. The CBM8221S, CBM8222S include a shutdown mode. Under logic control, the amplifiers can be switched from normal operation to a standby current that is less than 1uA. The CBM8221, CBM8222, CBM8224, CBM8221S, CBM8222S families of operational amplifiers are specified at the full temperature range of -40°C to +125°C under single or dual power supplies of 2.5V to 5.5V.

## CATALOG

Features.....	
Application.....	
Description.....	
Pin Configurations.....	1
Electrical Characteristics.....	3
Typical Characteristics.....	6
Application Notes.....	8
CBM8221S/CBM8222S ENABLE FUNCTION.....	8
Layout Guidelines.....	9
Instrumentation Amplifier.....	9
Package Outline Dimensions.....	10
SOT23-5.....	10
SOT23-6.....	11
MSOP-8.....	12
MSOP-10.....	13
TSSOP-14.....	14
SOIC-8(SOP8).....	15
SOIC-14(SOP14).....	16
TDFN-3×3-8L.....	17
Package/Ordering Information.....	18

## Pin Configurations

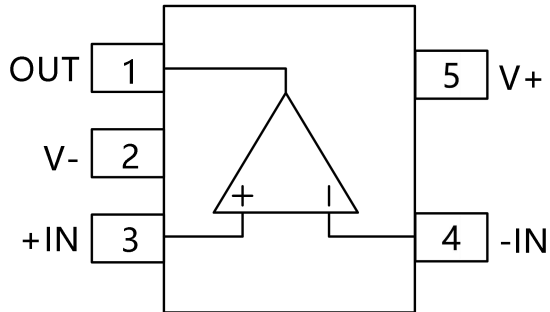

**SOT23-5**

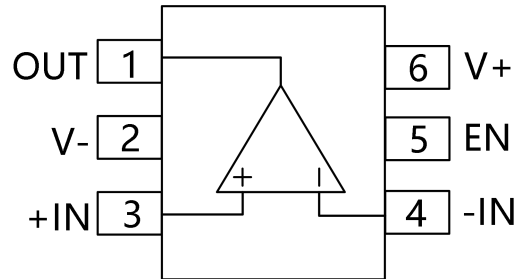

**SOT23-6**

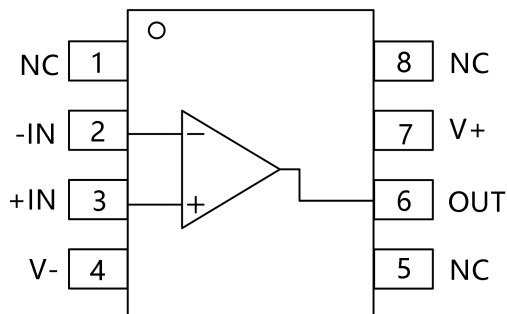

**SOIC-8(SOP8) , MSOP-8**

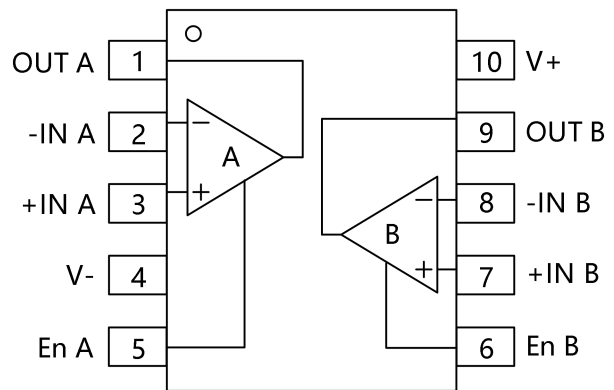

**MSOP-10**

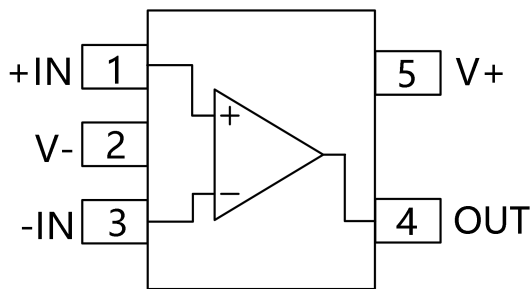

**SOT23-5**

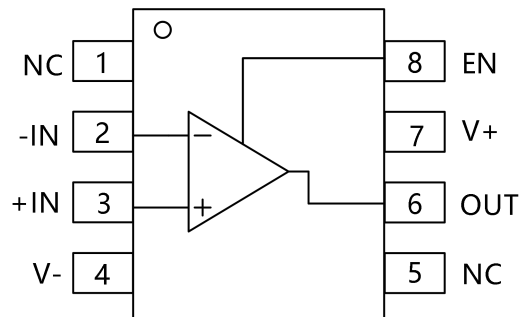

**SOIC-8(SOP8)**

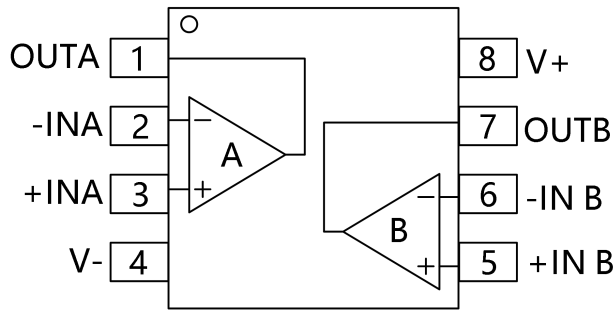

**SOIC-8(SOP8),MSOP-8**

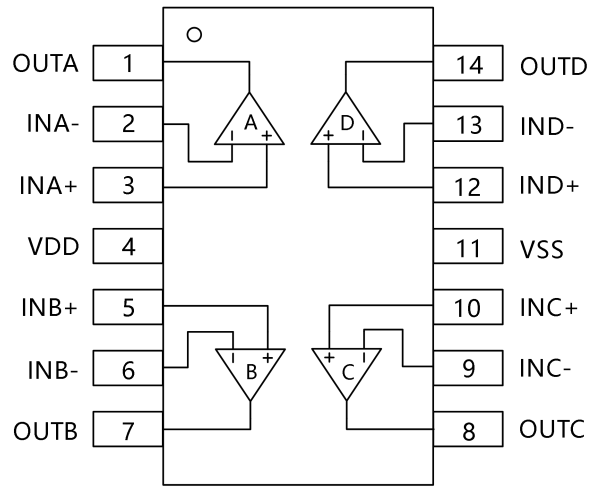

**SOIC-14(SOP14),TSSOP-14**

## Electrical Characteristics

- ..Supply Voltage, V+ to V-..... 7.0V
- ..Input Terminals, Voltage <sup>(2)</sup>.....- 0.5 to (V+) + 0.5V  
Current <sup>(2)</sup>..... ±10mA
- ..Storage Temperature..... -65°C to +150°C
- ..Operating Temperature..... -40°C to +125°C
- ..Junction Temperature..... 150°C
- ..Package Thermal Resistance @ TA= +25°C
- ..SOT23-5, SOT23-6..... 200°C/W
- ..MSOP-10, SOIC-8, TSSOP-8..... 150°C/W
- ..SOIC-14, TSSOP-14..... 100°C/W
- ..Lead Temperature (Soldering, 10s)..... 260°C ESD Susceptibility
- ..HBM..... 5000V
- ..MM..... 400V

1.Stresses above these ratings may cause permanent damage. Exposure to absolute maximum conditions for extended periods may degrade device reliability. These are stress ratings only, and functional operation of the device at these or any other conditions beyond those specified is not implied.

2.Input terminals are diode-clamped to the power-supply rails. Input signals that can swing more than 0.5V beyond the supply rails should be current-limited to 10mA or less.



### ESD SENSITIVITY CAUTION

ESD damage can range from subtle performance degradation to complete device failure. Precision integrated circuits may be more susceptible to damage because very small parametric changes could cause the device not to meet its published specifications.

## Electrical Characteristics

(At  $T_A = +25^\circ\text{C}$ ,  $V_S = 5\text{V}$ ,  $R_L = 10\text{k}\Omega$  connected to  $V_S/2$ , and  $V_{\text{OUT}} = V_S/2$ , unless otherwise noted.)

PARAMETER		CONDITIONS	$T_J$	CBM8541, CBM8542, CBM8544			UNIT
				MIN	TYP	MAX	
<b>POWER SUPPLY</b>							
$V_S$	Operating Voltage Range		25°C	2.5		5.5	V
$I_Q$	Quiescent Current/Amplifier		25°C		18	32	$\mu\text{A}$
$P_{\text{SRR}}$	Power-Supply Rejection Ratio	$V_S = 2.5\text{V to } 5.5\text{V}$ , $V_{\text{CM}} = (V_-) + 0.5\text{V}$	25°C	73	90		dB
			-40°C to 125°C	67			
<b>INPUT</b>							
$V_{\text{OS}}$	Input Offset Voltage		25°C		0.8	3.5	mV
$V_{\text{OS TC}}$	Input Offset Voltage Average Drift	-40°C to 125°C			2.9		$\mu\text{V}/^\circ\text{C}$
$I_B$	Input Bias Current		25°C		1	10	pA
$I_{\text{OS}}$	Input Offset Current		25°C		1	10	pA
$V_{\text{CM}}$	Common-Mode Voltage Range	$V_S = 5.5\text{V}$	25°C	-0.1		5.6	V
$C_{\text{MRR}}$	Common-Mode Rejection Ratio	$V_S = 5.5\text{V}$ , $V_{\text{CM}} = -0.1\text{V to } 4\text{V}$	25°C	74	90		dB
			-40°C to 125°C	70			
			25°C	62	75		
			-40°C to 125°C	60			
<b>OUTPUT</b>							
$A_{\text{OL}}$	Open-Loop Voltage Gain	$R_L = 2\text{k}\Omega$ , $V_O = 0.15\text{V to } 4.85\text{V}$	25°C	88	98		dB
			-40°C to 125°C	82			
			25°C	92	110		
			-40°C to 125°C	88			
	Output Swing From Rail	$R_L = 2\text{k}\Omega$	25°C		26		mV
				$R_L = 10\text{k}\Omega$		6	
$I_{\text{OUT}}$	Output Short-Circuit Current		25°C		27		mA

FREQUENCY RESPONSE							
$S_R$	Slew Rate		25°C		0.18		V/us
$G_{BP}$	Gain-Bandwidth Product		25°C		500		KHz
$P_M$	Phase Margin		25°C		64		°
$t_S$	Setting Time,0.1%				14		us
	Overload Recovery Time	$V_{IN} \cdot Gain \geq V_S$			5		us
NOISE							
$e_n$	Input Voltage Noise Density	$f = 1\text{KHz}$	25°C		77		$nV/\sqrt{Hz}$
		$f = 10\text{KHz}$	25°C		39		$nV/\sqrt{Hz}$
ENABLE/SHUTDOWN(CBM8541,CBM8542)							
$I_{Q(OFF)}$	Supply Current in Shutdown		25°C		<1		uA
$t_{OFF}$			25°C		3		us
$t_{ON}$			25°C		20		us
$V_L$	Shut Down		25°C	V-		(V-)+0.8	V
$V_H$	Amplifier Is Active		25°C	(V-)+2		V+	V

## Typical Characteristics

At  $T_A = +25^\circ\text{C}$ ,  $V_S = 5\text{V}$ ,  $R_L = 200\text{k}\Omega$  connected to  $V_S/2$ ,  $V_{OUT} = V_S/2$ , unless otherwise noted.

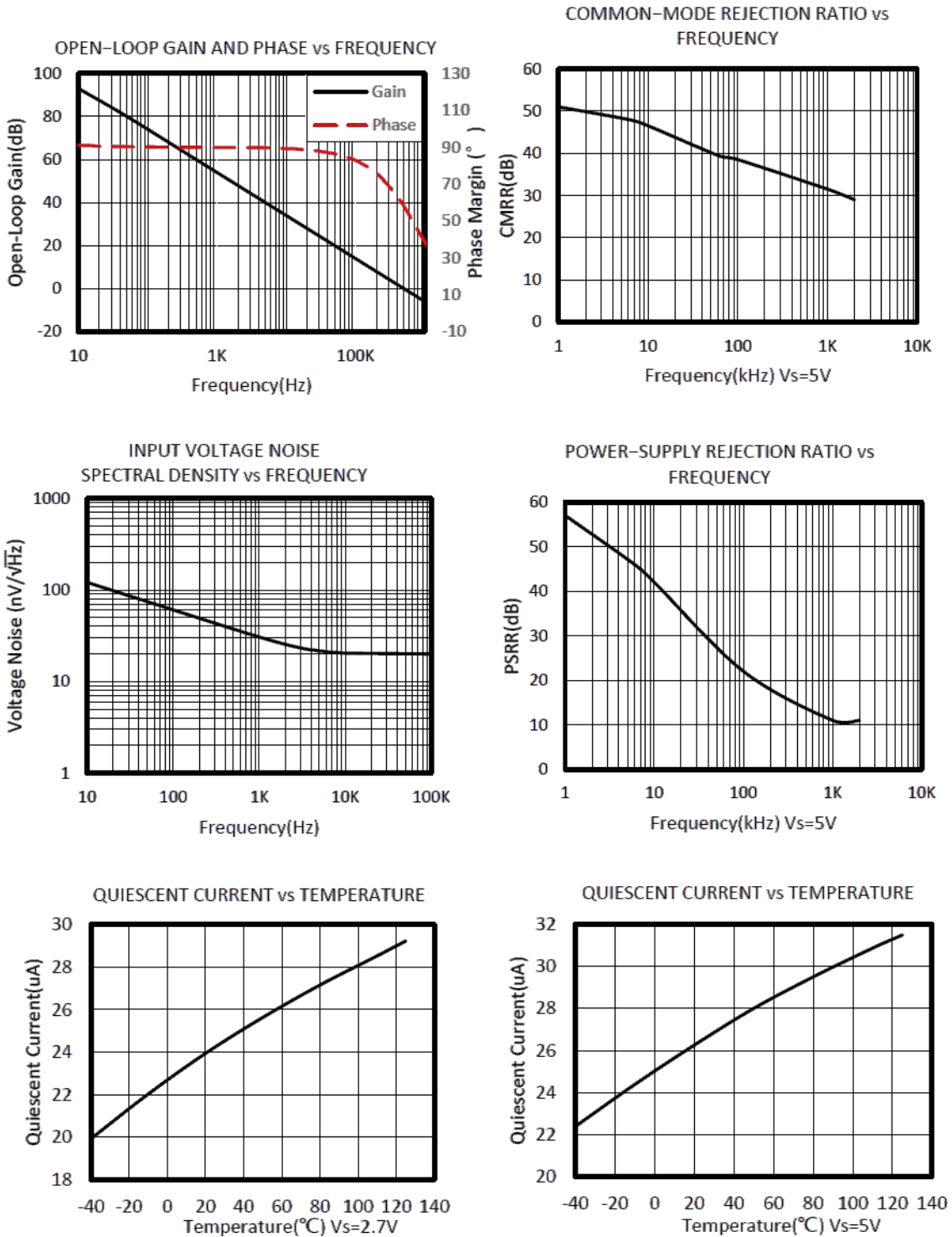



## Typical Characteristics

At  $T_A = +25^\circ\text{C}$ ,  $V_S = 5\text{V}$ ,  $R_L = 200\text{ k}\Omega$  connected to  $V_S/2$  and  $V_{OUT} = V_S/2$ , unless otherwise noted.

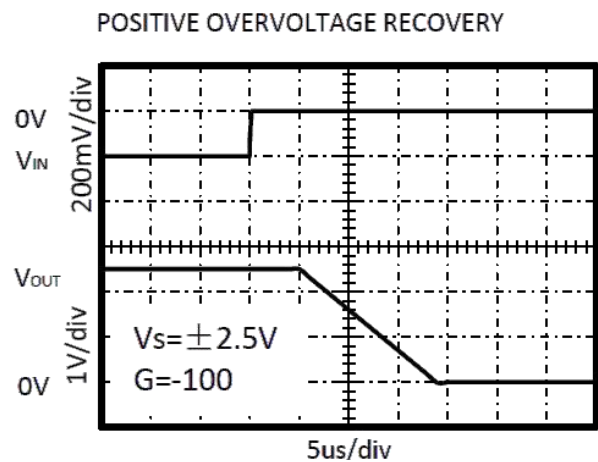
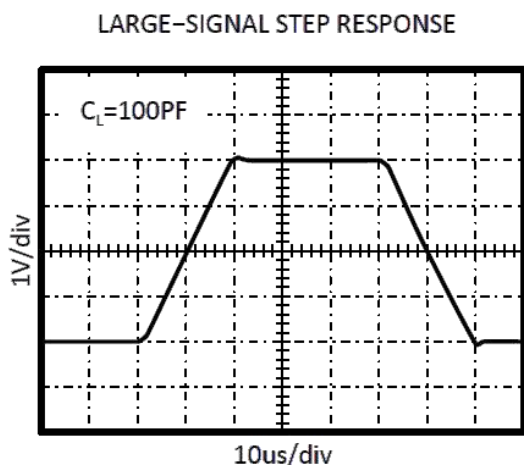
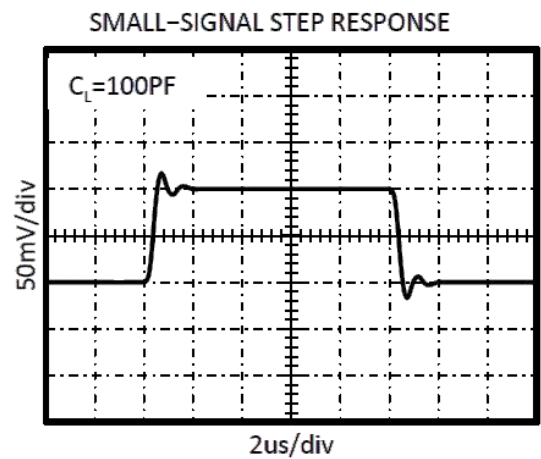
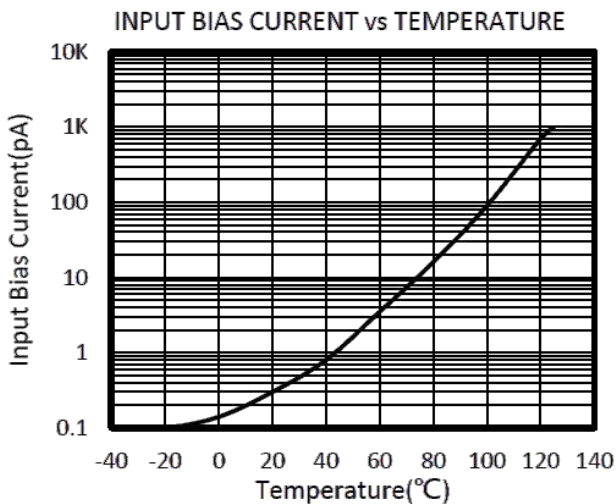
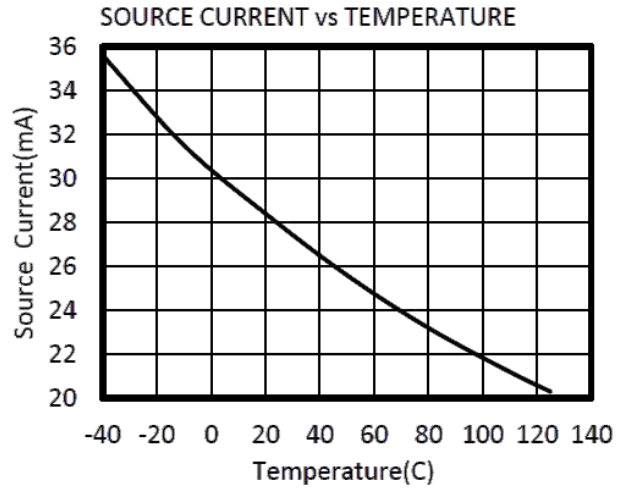
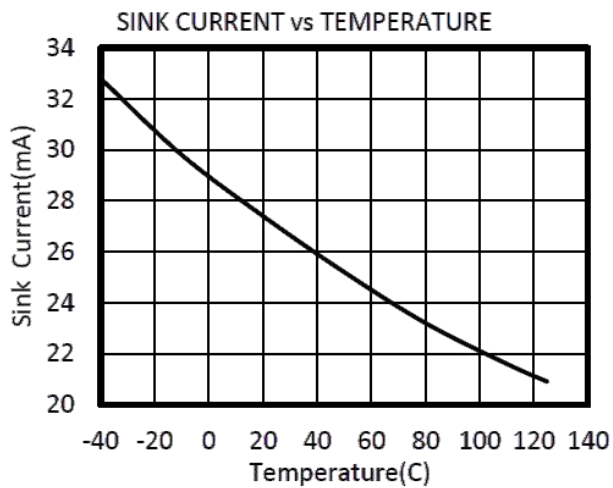

## Typical Characteristics

At  $T_A = +25^\circ\text{C}$ ,  $V_S = 5\text{V}$ ,  $R_L = 200\text{k}\Omega$  connected to  $V_S/2$ ,  $V_{OUT} = V_S/2$ , unless otherwise noted.

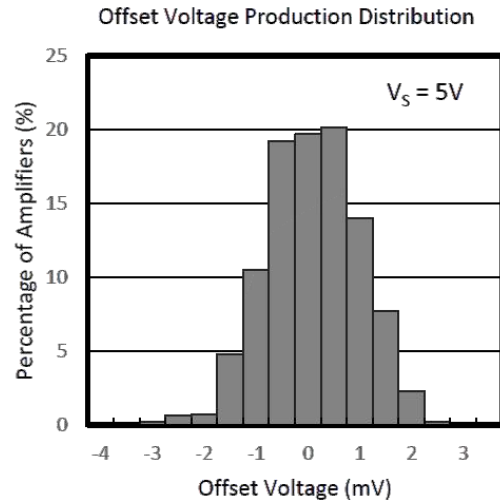
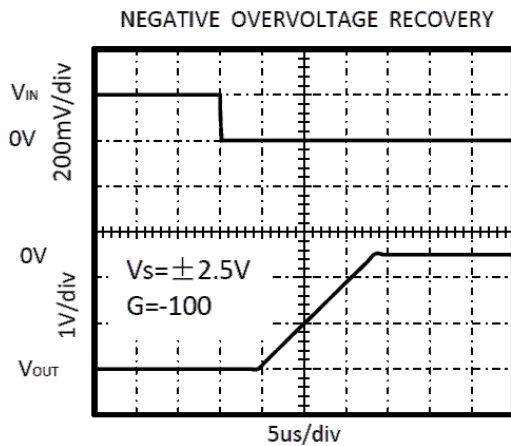

## Application Notes

The CBM8221, CBM8222, CBM8224, CBM8221S, CBM8222S are high precision, rail-to-rail operational amplifiers that can be run from a single-supply voltage 2.5V to 5.5V ( $\pm 1.25\text{V}$  to  $\pm 2.75\text{V}$ ). Supply voltages higher than 7V (absolute maximum) can permanently damage the amplifier.

Rail-to-rail input and output swing significantly increases dynamic range, especially in low-supply applications.

Good layout practice mandates use of a 0.1 $\mu\text{F}$  capacitor place closely across the supply pins.

## CBM8221S/CBM8222S ENABLE FUNCTION

The CBM8221S/CBM8222S includes a shutdown mode. Under logic control, the amplifiers can be switched from normal mode to a standby current of 1 $\mu\text{A}$ . When the Enable pin is connected to high, the amplifier is active. Connecting Enable low disables the amplifier, and places the amplifier, and place the output in a high-impedance state.

## Layout Guidelines

Attention to good layout practices is always recommended. Keep traces short. When possible, use a PCB ground plane with surface-mount components placed as close to the device pins as possible. Place a 0.1uF capacitor closely across the supply pins.

These guidelines should be applied throughout the analog circuit to improve performance and provide benefits such as reducing the EMI susceptibility.

## Instrumentation Amplifier

In the three-op amp, instrumentation amplifier configuration shown in Figure2.

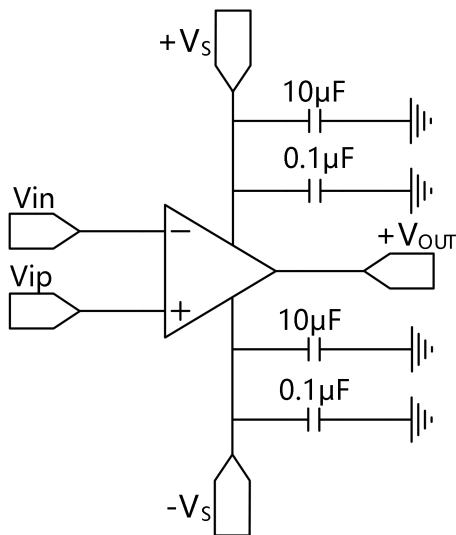

Figure 1. Amplifier with Bypass Capacitors

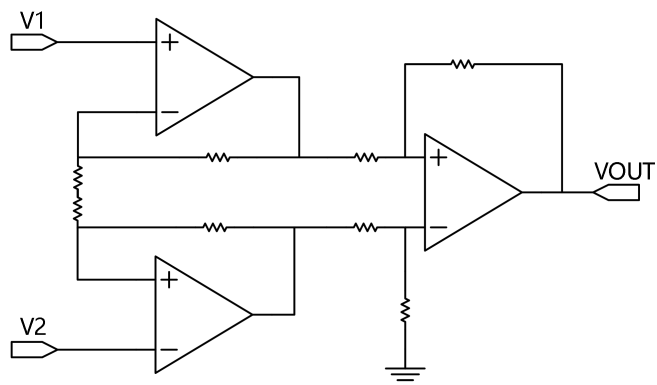
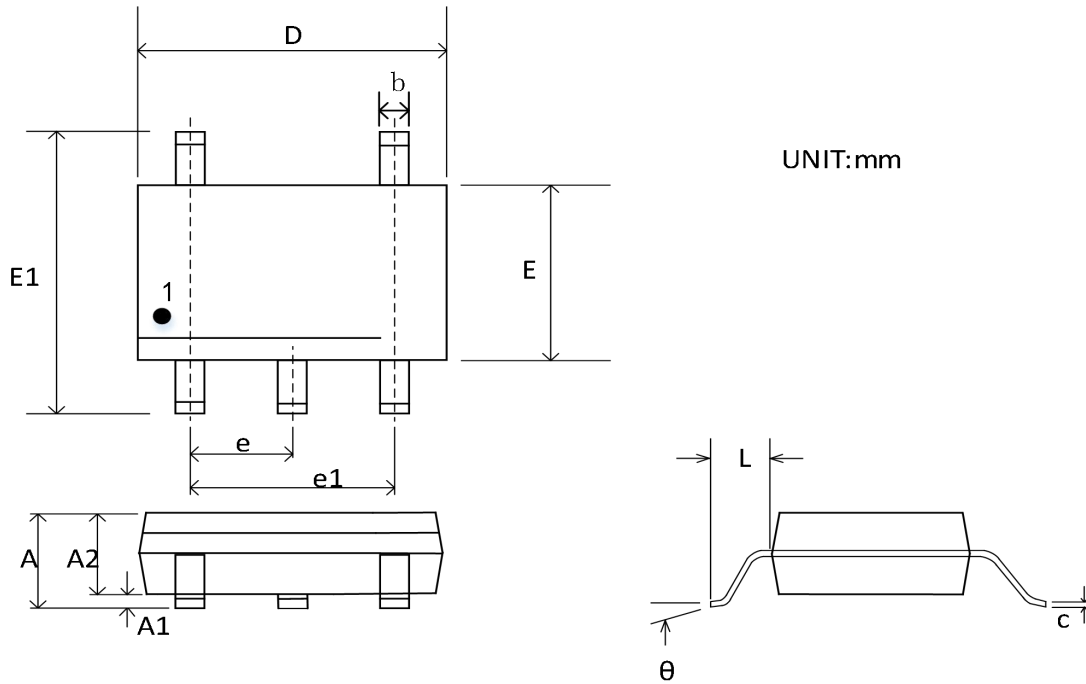

Figure2. Amplifier instrumentation amplifier

## Package Outline Dimensions

### SOT23-5



Symbol	Dimensions In Millimeters		Dimensions Inches	
	Min	Max	Min	Max
<b>A</b>	1.050	1.250	0.041	0.049
<b>A1</b>	0.000	0.100	0.000	0.004
<b>A2</b>	1.050	1.150	0.041	0.045
<b>b</b>	0.300	0.500	0.012	0.020
<b>c</b>	0.100	0.200	0.004	0.008
<b>D</b>	2.820	3.020	0.111	0.119
<b>E</b>	1.500	1.700	0.059	0.067
<b>E1</b>	2.650	2.950	0.104	0.116
<b>e</b>	0.950 BSC		0.037 BSC	
<b>e1</b>	1.800	2.000	0.071	0.079
<b>L</b>	0.300	0.600	0.012	0.024
<b>θ</b>	0°	8°	0°	8°

## SOT23-6

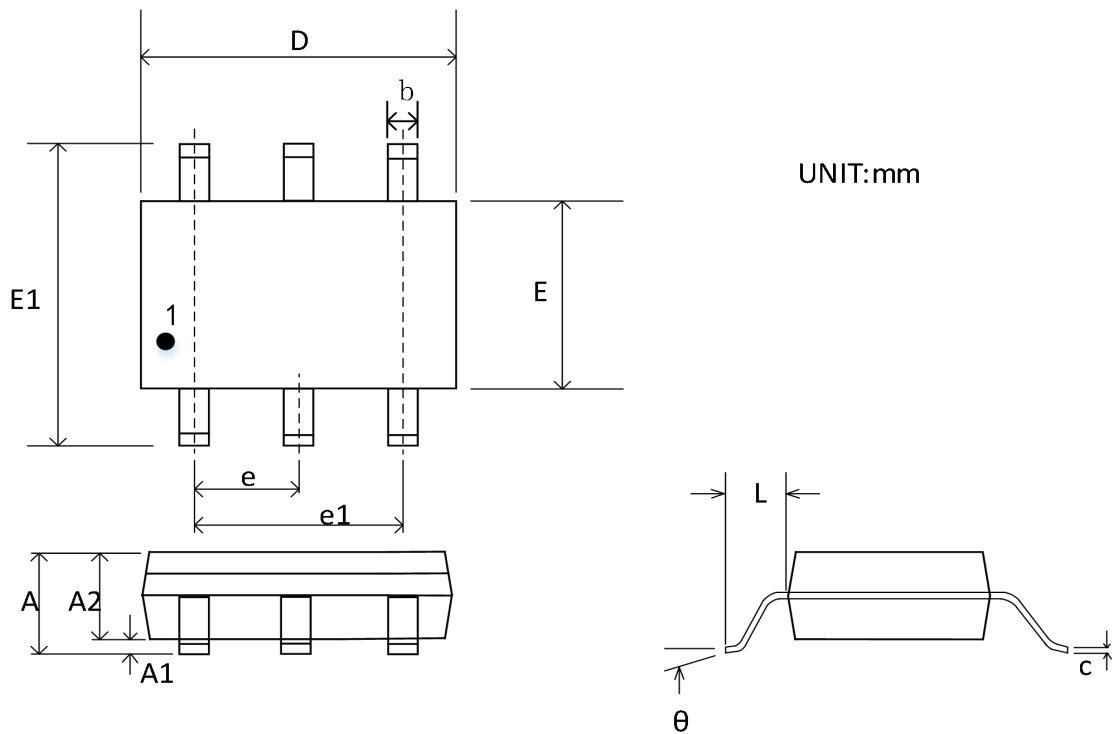

Symbol	Dimensions In Millimeters		Dimensions Inches	
	Min	Max	Min	Max
<b>A</b>	1.050	1.250	0.041	0.049
<b>A1</b>	0.000	0.100	0.000	0.004
<b>A2</b>	1.050	1.150	0.041	0.045
<b>b</b>	0.300	0.500	0.012	0.020
<b>c</b>	0.100	0.200	0.004	0.008
<b>D</b>	2.820	3.020	0.111	0.119
<b>E</b>	1.500	1.700	0.059	0.067
<b>E1</b>	2.650	2.950	0.104	0.116
<b>e</b>	0.950 BSC		0.037 BSC	
<b>e1</b>	1.900 BSC	0.075 BSC		
<b>L</b>	0.300		0.600	
<b>θ</b>	0°	8°	0°	8°

## MSOP-8

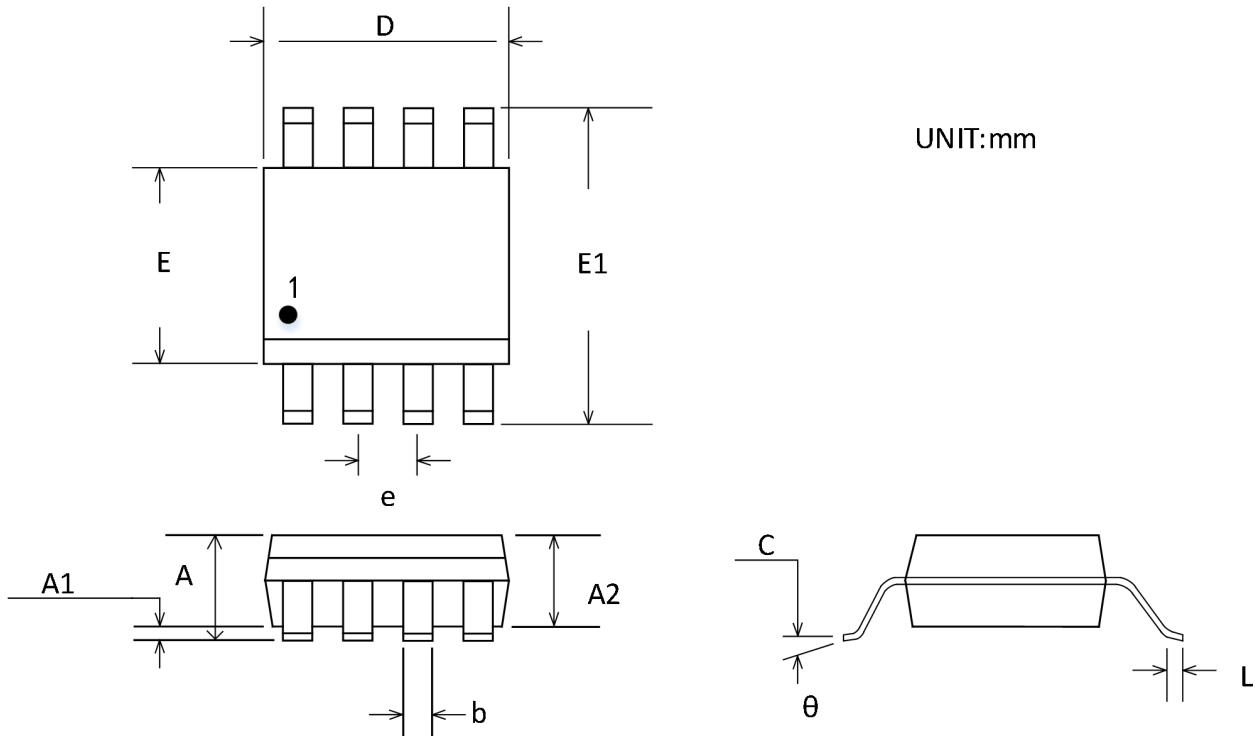

Symbol	Dimensions In Millimeters		Dimensions Inches	
	Min	Max	Min	Max
<b>A</b>	0.820	1.100	0.032	0.043
<b>A1</b>	0.020	0.150	0.001	0.006
<b>A2</b>	0.750	0.950	0.030	0.037
<b>b</b>	0.250	0.380	0.010	0.015
<b>c</b>	0.090	0.230	0.004	0.009
<b>D</b>	2.900	3.100	0.114	0.122
<b>E</b>	2.900	3.100	0.114	0.122
<b>E1</b>	4.750	5.050	0.187	0.199
<b>e</b>	0.650 BSC		0.026 BSC	
<b>L</b>	0.400	0.800	0.016	0.031
<b>θ</b>	0°	6°	0°	6°

## MSOP-10

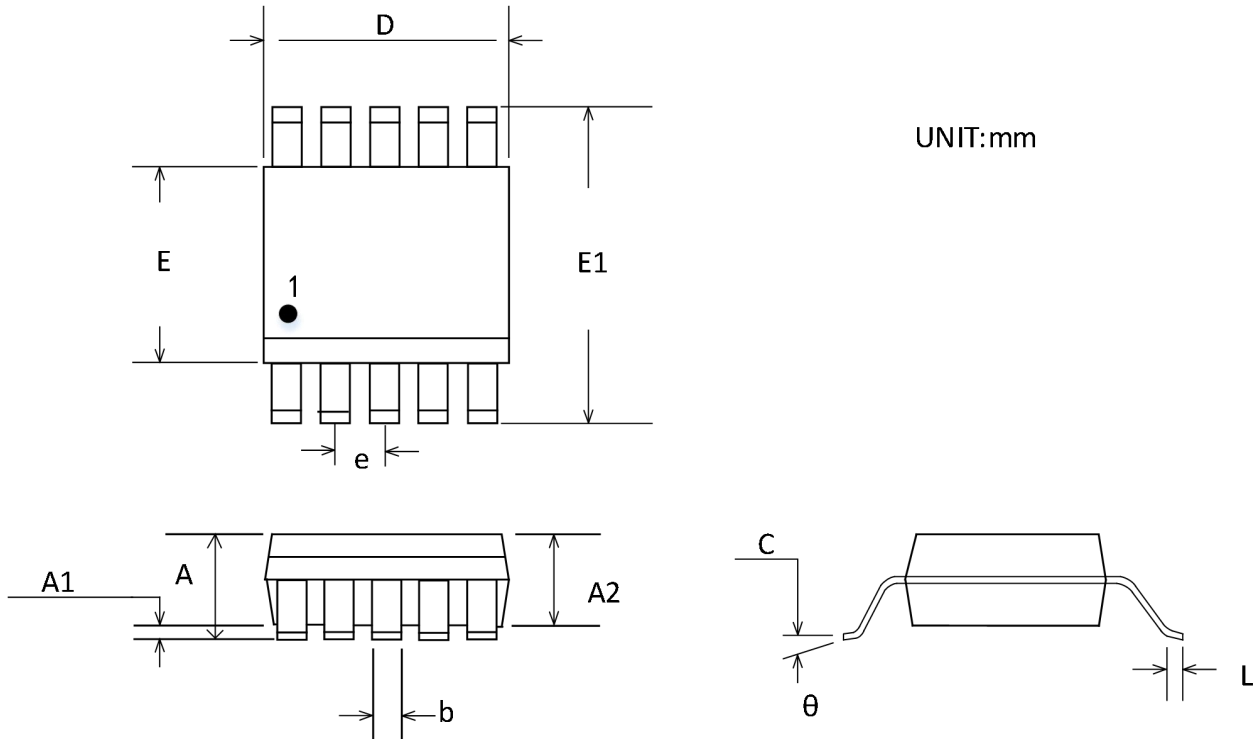

Symbol	Dimensions In Millimeters		Dimensions Inches	
	Min	Max	Min	Max
A	0.820	1.100	0.032	0.043
A1	0.020	0.150	0.001	0.006
A2	0.750	0.950	0.030	0.037
b	0.180	0.280	0.007	0.011
c	0.090	0.230	0.004	0.009
D	2.900	3.100	0.114	0.122
E	2.900	3.100	0.114	0.122
E1	4.750	5.050	0.187	0.199
e	0.50 BSC		0.020 BSC	
L	0.400	0.800	0.016	0.031
θ	0°	6°	0°	6°

## TSSOP-14

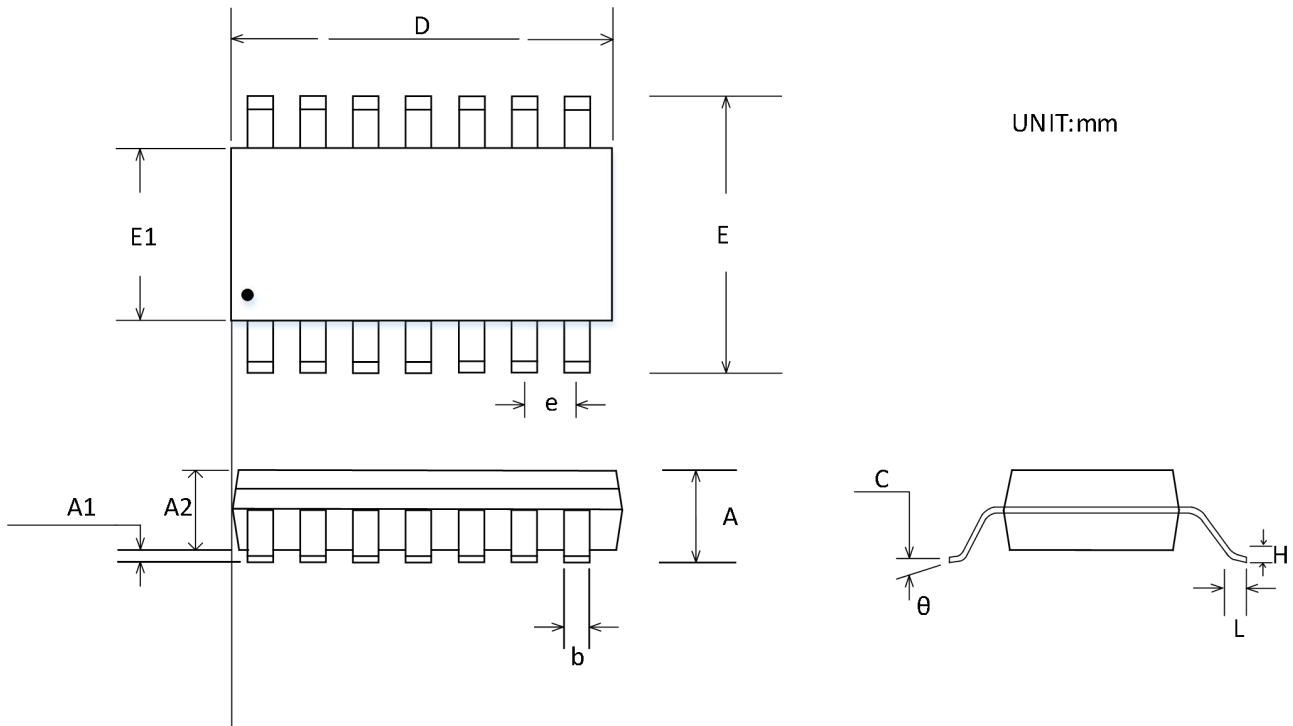

Symbol	Dimensions In Millimeters		Dimensions Inches	
	Min	Max	Min	Max
<b>A</b>		1.200		0.047
<b>A1</b>	0.050	0.150	0.002	0.006
<b>A2</b>	0.800	1.050	0.031	0.041
<b>b</b>	0.190	0.300	0.007	0.012
<b>c</b>	0.090	0.200	0.004	0.008
<b>D</b>	4.860	5.100	0.191	0.201
<b>E</b>	4.300	4.500	0.169	0.177
<b>E1</b>	6.250	6.550	0.246	0.258
<b>e</b>	0.650 BSC		0.026 BSC	
<b>L</b>	0.500	0.700	0.020	0.028
<b>H</b>	0.25 TYP		0.01 TYP	
<b>θ</b>	1°	7°	1°	7°



## SOIC-8(SOP8)

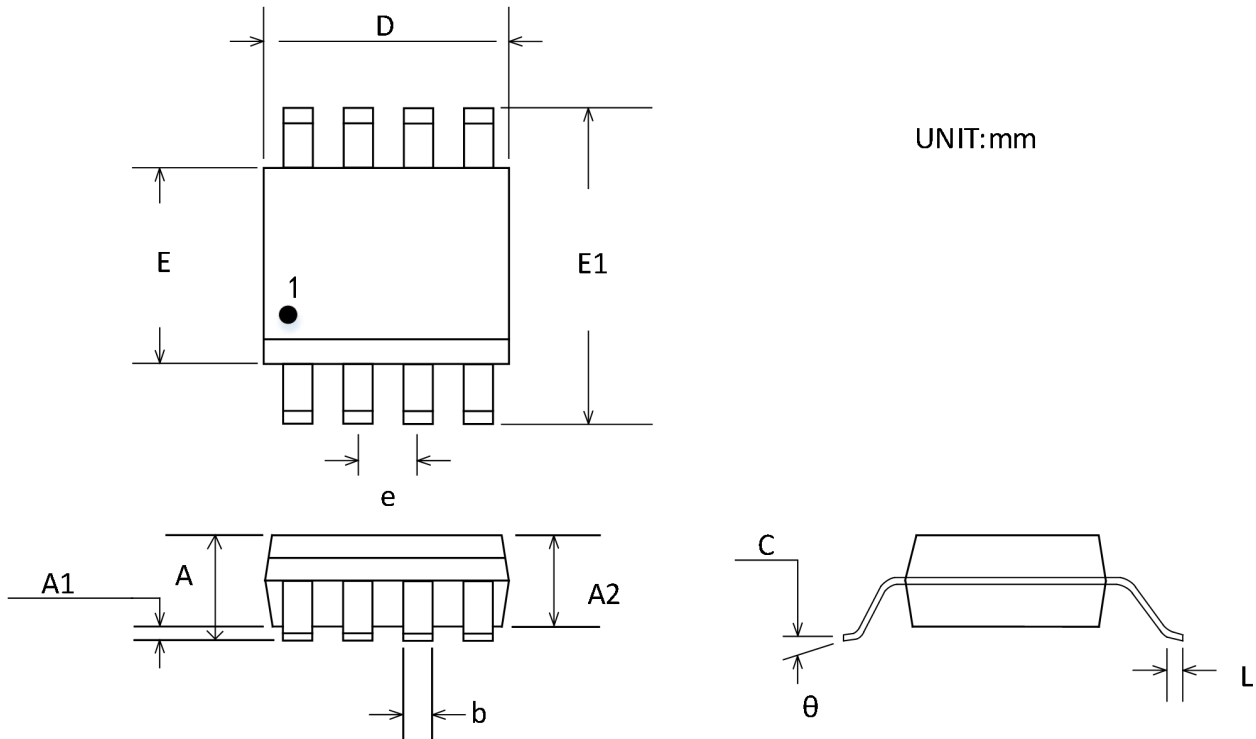

Symbol	Dimensions In Millimeters		Dimensions Inches	
	Min	Max	Min	Max
<b>A</b>	1.350	1.750	0.053	0.069
<b>A1</b>	0.100	0.250	0.004	0.010
<b>A2</b>	1.350	1.550	0.053	0.061
<b>b</b>	0.330	0.510	0.013	0.020
<b>c</b>	0.170	0.250	0.007	0.010
<b>D</b>	4.800	5.000	0.189	0.197
<b>E</b>	5.800	6.200	0.228	0.244
<b>E1</b>	3.800	4.000	0.150	0.157
<b>e</b>	1.270 BSC		0.050 BSC	
<b>L</b>	0.400	1.270	0.016	0.050
<b>θ</b>	0°	8°	0°	8°

## SOIC-14(SOP14)

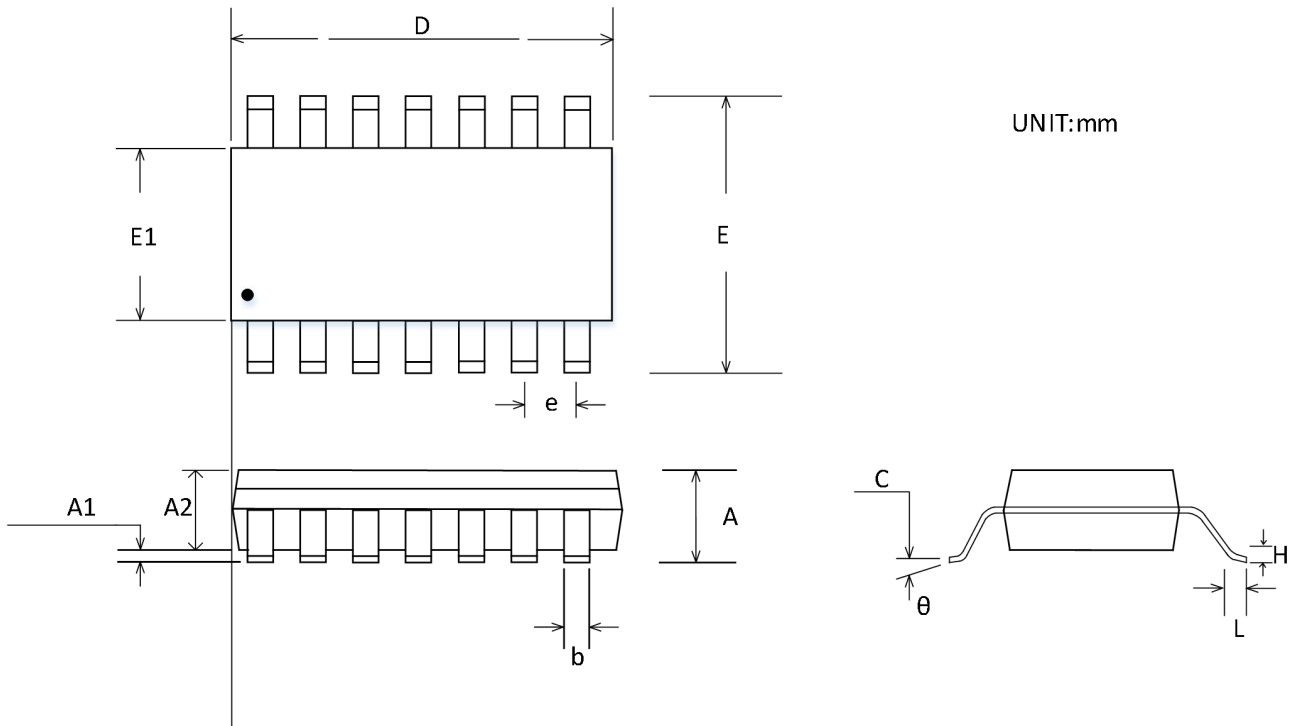

Symbol	Dimensions In Millimeters		Dimensions Inches	
	Min	Max	Min	Max
<b>A</b>	1.350	1.750	0.053	0.069
<b>A1</b>	0.100	0.250	0.004	0.010
<b>A2</b>	1.350	1.550	0.053	0.061
<b>b</b>	0.310	0.510	0.012	0.020
<b>c</b>	0.100	0.250	0.004	0.010
<b>D</b>	8.450	8.850	0.333	0.348
<b>E</b>	5.800	6.200	0.228	0.244
<b>E1</b>	3.800	4.000	0.150	0.157
<b>e</b>	1.270 BSC		0.050 BSC	
<b>L</b>	0.400	1.270	0.016	0.050
<b>θ</b>	0°	8°	0°	8°

## TDFN-3×3-8L

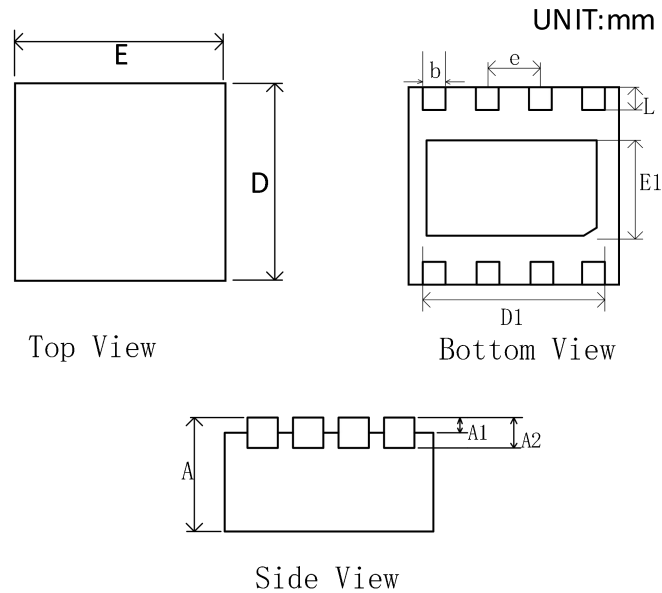

Symbol	Dimensions In Millimeters		Dimensions Inches	
	Min	Max	Min	Max
<b>A</b>	0.700	0.800	0.028	0.031
<b>A1</b>	0.000	0.050	0.000	0.002
<b>A2</b>	0.203 TYP		0.008 TYP	
<b>b</b>	0.250	0.350	0.010	0.014
<b>D</b>	2.900	3.100	0.114	0.122
<b>D1</b>	2.350	2.450	0.093	0.096
<b>E</b>	2.900	3.100	0.114	0.122
<b>E1</b>	1.650	1.750	0.065	0.069
<b>e</b>	0.650 TYP		0.026 TYP	
<b>L</b>	0.370	0.470	0.015	0.019

## Package/Ordering Information

PRODUCT TYPE	OPERATING TEMPERATURE	PACKAGE	PACKAGE MARKING	NUMBER OF PACKAGES
CBM8221AS8	-40°C~125°C	SOIC-8(SOP8)	CBM8221	Tape and Reel, 2500
CBM8221AS8-RL	-40°C~125°C	SOIC-8(SOP8)	CBM8221	Tape and Reel, 3000
CBM8221AS8-REEL	-40°C~125°C	SOIC-8(SOP8)	CBM8221	Tape and Reel, 4000
CBM8221AST5	-40°C~125°C	SOT23-5	221	Tape and Reel, 3000
CBM8221BST5	-40°C~125°C	SOT23-5	221B	Tape and Reel, 3000
CBM8221AMS8	-40°C~125°C	MSOP-8	CBM8221	Tape and Reel, 3000
CBM8221SAS8	-40°C~125°C	SOIC-8(SOP8)	CBM8221S	Tape and Reel, 2500
CBM8221SAS8-RL	-40°C~125°C	SOIC-8(SOP8)	CBM8221S	Tape and Reel, 3000
CBM8221SAS8-REEL	-40°C~125°C	SOIC-8(SOP8)	CBM8221S	Tape and Reel, 4000
CBM8221SAST6	-40°C~125°C	SOT23-6	221S	Tape and Reel, 3000
CBM8222AS8	-40°C~125°C	SOIC-8(SOP8)	CBM8222	Tape and Reel, 2500
CBM8222AS8-RL	-40°C~125°C	SOIC-8(SOP8)	CBM8222	Tape and Reel, 3000
CBM8222AS8-REEL	-40°C~125°C	SOIC-8(SOP8)	CBM8222	Tape and Reel, 4000
CBM8222AMS8	-40°C~125°C	MSOP-8	CBM8222	Tape and Reel, 3000
CBM8222SAMS	-40°C~125°C	MSOP-10	CBM8222S	Tape and Reel, 3000
CBM8224AS14	-40°C~125°C	SOIC-14(SOP14)	CBM8224AS	Tape and Reel, 2500
CBM8224AS14-RL	-40°C~125°C	SOIC-14(SOP14)	CBM8224AS	Tape and Reel, 3000
CBM8224AS14-REEL	-40°C~125°C	SOIC-14(SOP14)	CBM8224AS	Tape and Reel, 4000
CBM8224ATS14	-40°C~125°C	TSSOP-14	CBM8224AT	Tape and Reel, 2500
CBM8224ATS14-RL	-40°C~125°C	TSSOP-14	CBM8224T	Tape and Reel, 3000
CBM8224ATS14-REEL	-40°C~125°C	TSSOP-14	CBM8224AT	Tape and Reel, 4000