

## Features

- SNR: 79dBFS (9.7MHz,  $V_{REF}=1.4V$ )
- SNR: 77dBFS (9.7MHz,  $V_{REF}=1.0V$ )
- SFDR: 85dBc to Nyquist( $V_{REF}=1.4V$ )
- SFDR: 91dBc to Nyquist( $V_{REF}=1.0V$ )
- JESD204B Subclass 1 coded serial digital outputs
- Flexible analog input range: 2.0 V p-p to 2.8 V p-p
- 1.8 V supply operation
- Low power: 195 mW per channel at 125 MSPS (two lanes)
- DNL =  $\pm 0.6$  LSB ( $V_{REF} = 1.4$  V)
- INL =  $\pm 5.0$  LSB ( $V_{REF} = 1.4$  V)
- 650 MHz analog input bandwidth, full power
- Serial port control
- Full chip and individual channel power-down modes
- Built-in and custom digital test pattern generation
- Multichip sync and clock divider
- Standby mode

## Applications

- High speed imaging
- Quadrature radio receivers
- Diversity radio receivers
- Portable test equipment

## Description

The CBM96AD56-125 is a quad, 16-bit, 125 MSPS analog-to-digital converter (ADC) with an on-chip sample and hold circuit designed for low cost, low power, small size, and ease of use. The device operates at a conversion rate of up to 125 MSPS and is optimized for outstanding dynamic performance and low power in applications where a small package size is critical.

The ADC requires a single 1.8 V power supply and LVPECL-/ CMOS-/LVDS-compatible sample rate clock for full performance operation. An external reference or driver components are not required for many applications.

Individual channel power-down is supported and typically consumes less than 14 mW when all channels are disabled. The ADC contains several features designed to maximize flexibility and

minimize system cost, such as a programmable output clock, data alignment, and digital test pattern generation. The available digital test patterns include built-in deterministic and pseudo-random patterns, along with custom user-defined test patterns entered via the serial port interface (SPI).

## Catalog

Features.....	1
Applications.....	1
Description.....	1
Catalog.....	3
Functional Block Diagram.....	4
Product Highlights.....	4
Electrical characteristics.....	5
DC Specifications, $V_{REF} = 1.4\text{ V}$ .....	5
DC Specifications, $V_{REF} = 1.0\text{ V}$ .....	6
AC Specifications, $V_{REF} = 1.4\text{ V}$ .....	7
AC Specifications, $V_{REF} = 1.0\text{ V}$ .....	9
Digital Specifications .....	11
Switching Specifications .....	13
Timing Specifications .....	14
Absolute Maximum Ratings .....	16
Pin Configuration and Function Descriptions .....	17
Typical Performance Characteristics .....	19
$V_{REF} = 1.4\text{ V}$ .....	19
$V_{REF} = 1.0\text{ V}$ .....	20
Equivalent Circuits .....	22
Theory of Operation .....	23
Analog Input Considerations .....	23
Input common mode level.....	24
Differential input configuration.....	25
Voltage Reference .....	26
External reference voltage.....	28
Clock Input Considerations .....	28
Clock input options.....	28
Input clock divider.....	30
Jitter considerations.....	31
Power consumption and power saving mode.....	32
Digital output.....	33
Memory map.....	45
Applications Information .....	58
Package Outline Dimensions .....	60
Package/Ordering Information .....	61

## Function Block Diagram

This product adopts 56-pin package. It is specified over the  $-40^{\circ}\text{C}$  to  $+85^{\circ}\text{C}$

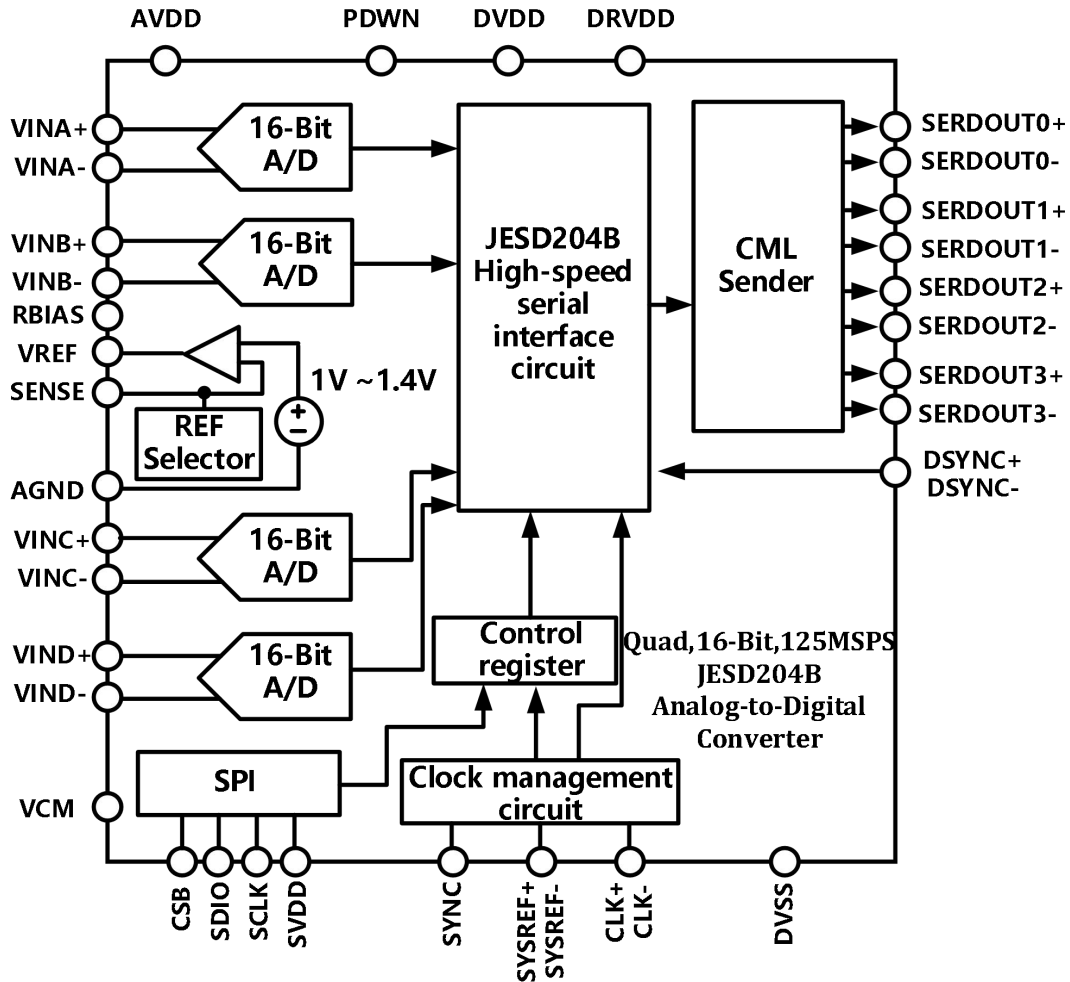

Figure1. Functional Block Diagram

## Product Highlights

1. It has a small footprint. Four ADCs are contained in a small,  $8\text{ mm} \times 8\text{ mm}$  package.
2. An on-chip phase-locked loop (PLL) allows users to provide a single ADC sampling clock; the PLL multiplies the ADC sampling clock to produce the corresponding JESD204B data rate clock.
3. The configurable JESD204B output block supports up to 6.4 Gbps per lane.
4. JESD204B output block supports one, two, and four lane configurations.

5. Low power of 200 mW per channel at 125 MSPS, two lanes.
6. The SPI control offers a wide range of flexible features to meet specific system requirements.

## Electrical characteristics

### ● DC Specifications( $V_{REF}=1.4\text{ V}$ )

AVDD = 1.8 V, DRVDD = 1.8 V, 2.8 V p-p full-scale differential input, 1.4 V reference,  $A_{IN} = -1.0$  dBFS, unless otherwise noted.

Table1.

Parameter	Temperature	Min	Typ	Max	Unit
RESOLUTION	25°C		16		Bits
<b>ACCURACY</b>					
No Missing Codes	25°C		Guaranteed		
Offset Error	25°C		0.2		%FSR
Offset Matching	25°C		0.05		%FSR
Gain Error	25°C		1.2		%FSR
Gain Matching	25°C		0.95		%FSR
Differential Nonlinearity(DNL)	25°C		±0.5		LSB
Integral Nonlinearity(INL)	25°C		±5.0		LSB
<b>TEMPERATURE DRIFT</b>					
Gain Error	Full		5.2		ppm/°C
Offset Error	Full		-2.5		ppm/°C
<b>INTERNAL VOLTAGE REFERENCE</b>					
Output Voltage	25°C		1.4		V
Load Regulation at 1.0 mA	25°C		4		mV
Input Resistance	25°C		7.5		kΩ
<b>INPUT REFERRED NOISE</b>					
$V_{REF}=1.4V$	25°C		2.1		LSB rms
<b>ANALOG INPUTS</b>					
Differential Input Voltage	25°C		2.8		$V_{p-p}$
Common-Mode Voltage	25°C		0.9		V
Common-Mode Range	25°C	0.7		1.1	V
Differential Input Resistance	25°C		2.6		kΩ

Differential Input Capacitance	25°C		7		pF
<b>POWER SUPPLY</b>					
AVDD	25°C		1.8		V
DVDD、DRVDD	25°C		1.8		V
I <sub>AVDD</sub> (125MSPS、2 Lanes)	25°C		288		mA
I <sub>DVDD</sub> (125MSPS、2 Lanes)	25°C		67		mA
I <sub>DRVDD</sub> (125MSPS、2 Lanes)	25°C		83		mA
<b>TOTAL POWER CONSUMPTION</b>					
DC Input (125MSPS、2 Lanes)	25°C		706		mW
Sine Wave Input(125MSPS、2 Lanes)	25°C		788		mW
Power-Down Mode	25°C		14		mW
Standby Mode	25°C		547		mW

● **DC Specifications(V<sub>REF</sub>=1.0 V)**

AVDD = 1.8 V, DRVDD = 1.8 V, 2.0 V p-p full-scale differential input, 1.0 V reference, A<sub>IN</sub> = -1.0 dBFS, unless otherwise noted.

Table2.

Parameter	Temperature	Min	Typ	Max	Unit
RESOLUTION	25°C		16		Bits
<b>ACCURACY</b>					
No Missing Codes	25°C		Guaranteed		
Offset Error	25°C		0.2		%FSR
Offset Matching	25°C		0.13		%FSR
Gain Error	25°C		1.0		%FSR
Gain Matching	25°C		0.4		%FSR
Differential Nonlinearity(DNL)	25°C		±0.5		LSB
Integral Nonlinearity(INL)	25°C		±4.0		LSB
<b>TEMPERATURE DRIFT</b>					
Gain Error	Full		3.1		ppm/°C
Offset Error	Full		-3		ppm/°C
<b>INTERNAL VOLTAGE REFERENCE</b>					
Output Voltage	25°C		1.0		V
Load Regulation at 1.0 mA	25°C		2		mV

Input Resistance	25°C		7.5		kΩ
<b>INPUT REFERRED NOISE</b>					
$V_{REF}=1.4V$	25°C		2.7		LSB rms
<b>ANALOG INPUTS</b>					
Differential Input Voltage	25°C		2.0		$V_{p-p}$
Common-Mode Voltage	25°C		0.9		V
Common-Mode Range	25°C	0.5		1.3	V
Differential Input Resistance	25°C		2.6		kΩ
Differential Input Capacitance	25°C		7		pF
<b>POWER SUPPLY</b>					
AVDD	25°C		1.8		V
DVDD、DRVDD	25°C		1.8		V
$I_{AVDD}$ (125MSPS、2 Lanes)	25°C		276		mA
$I_{DVDD}$ (125MSPS、2 Lanes)	25°C		69		mA
$I_{DRVDD}$ (125MSPS、2 Lanes)	25°C		83		mA
<b>TOTAL POWER CONSUMPTION</b>					
DC Input (125MSPS、2 Lanes)	25°C		688		mW
Sine Wave Input(125MSPS、2 Lanes)	25°C		771		mW
Power-Down Mode	25°C		14		mW
Standby Mode	25°C		520		mW

● **AC Specifications( $V_{REF}=1.4 V$ )**

AVDD = 1.8 V, DRVDD = 1.8 V, 2.8 V p-p full-scale differential input, 1.4 V reference,  $A_{IN} = -1.0$  dBFS, 125 MSPS, unless otherwise noted.

Table3.

Parameter	Temperature	Min	Typ	Max	Unit
<b>SIGNAL-TO-NOISE(SNR)</b>					
$f_{IN} = 9.7MHz$	25°C		79.0		dBFS
$f_{IN} = 16MHz$	25°C		78.2		dBFS
$f_{IN} = 64MHz$	25°C		76.3		dBFS
$f_{IN} = 128MHz$	25°C		71.5		dBFS
$f_{IN} = 201MHz$	25°C		69.7		dBFS
$f_{IN} = 301MHz$	25°C		66.2		dBFS

<b>SIGNAL-TO-NOISE-AND-DISTORTION(SINAD)RATIO</b>					
$f_{IN} = 9.7\text{MHz}$	25°C		78.3		dBFS
$f_{IN} = 16\text{MHz}$	25°C		77.7		dBFS
$f_{IN} = 64\text{MHz}$	25°C		75.2		dBFS
$f_{IN} = 128\text{MHz}$	25°C		70.9		dBFS
$f_{IN} = 201\text{MHz}$	25°C		68.7		dBFS
$f_{IN} = 301\text{MHz}$	25°C		65.9		dBFS
<b>EFFECTIVE NUMBER OF BITS(ENOB)</b>					
$f_{IN} = 9.7\text{MHz}$	25°C		12.7		Bits
$f_{IN} = 16\text{MHz}$	25°C		12.6		Bits
$f_{IN} = 64\text{MHz}$	25°C		12.2		Bits
$f_{IN} = 128\text{MHz}$	25°C		11.5		Bits
$f_{IN} = 201\text{MHz}$	25°C		11.1		Bits
$f_{IN} = 301\text{MHz}$	25°C		10.7		Bits
<b>SPURIOUS-FREE DYNAMIC RANGE(SFDR)</b>					
$f_{IN} = 9.7\text{MHz}$	25°C		93.2		dBc
$f_{IN} = 16\text{MHz}$	25°C		90.1		dBc
$f_{IN} = 64\text{MHz}$	25°C		82.8		dBc
$f_{IN} = 128\text{MHz}$	25°C		82.3		dBc
$f_{IN} = 201\text{MHz}$	25°C		76.1		dBc
$f_{IN} = 301\text{MHz}$	25°C		82.3		dBc
<b>WORST HARMONIC(SECOND OR THIRD)</b>					
$f_{IN} = 9.7\text{MHz}$	25°C		93.2		dBc
$f_{IN} = 16\text{MHz}$	25°C		90.1		dBc
$f_{IN} = 64\text{MHz}$	25°C		82.8		dBc
$f_{IN} = 128\text{MHz}$	25°C		82.3		dBc
$f_{IN} = 201\text{MHz}$	25°C		76.1		dBc
$f_{IN} = 301\text{MHz}$	25°C		82.3		dBc
<b>WPRST OTHER SPUR OR HARMONIC(EXCLUDING SECOND OR THIRD)</b>					
$f_{IN} = 9.7\text{MHz}$	25°C		-96		dBc
$f_{IN} = 16\text{MHz}$	25°C		-92		dBc
$f_{IN} = 64\text{MHz}$	25°C		-90		dBc
$f_{IN} = 128\text{MHz}$	25°C		-89		dBc



$f_{IN} = 201\text{MHz}$	25°C		-93		dBc
$f_{IN} = 301\text{MHz}$	25°C		-90		dBc
<b>TWO-TONE INTERMODULATION DISTORTION(IMD)-INPUT AMPLITUDE=-7.0dBFS</b>					
$f_{IN1}=70.5\text{MHz}, f_{IN1}=72.5\text{MHz}$	25°C		-84		dBc
<b>CROSSTALK</b>					
CROSSTALK <sup>2</sup>	25°C		-93		dB
CROSSTALK(OVERRANGE CONDITION) <sup>3</sup>	25°C		-89		dB
<b>ANALOG INPUT BANDWIDTH, FULL POWER</b>	25°C		650		MHz

1. When  $f_{IN} \geq 401\text{MHz}$  is tested, the test shall be conducted under the condition of  $A_{IN} = -5.0\text{dBFS}$ .
2. Crosstalk is measured at 70 MHz with  $-1.0\text{ dBFS}$  analog input on one channel and no input on the adjacent channel.
3. Over range condition is defined as the input being 3 dB above full scale.

● **AC Specifications(VREF=1.0 V)**

AVDD = 1.8 V, DRVDD = 1.8 V, 2.0 V p-p full-scale differential input, 1.0 V reference,  $A_{IN} = -1.0\text{ dBFS}$ , 125 MSPS, unless otherwise noted.

Table 4.

Parameter	Temperature	Min	Typ	Max	Unit
<b>SIGNAL-TO-NOISE(SNR)</b>					
$f_{IN} = 9.7\text{MHz}$	25°C		77.4		dBFS
$f_{IN} = 16\text{MHz}$	25°C		77.1		dBFS
$f_{IN} = 64\text{MHz}$	25°C		75.3		dBFS
$f_{IN} = 128\text{MHz}$	25°C		71.9		dBFS
$f_{IN} = 201\text{MHz}$	25°C		69.2		dBFS
$f_{IN} = 301\text{MHz}$	25°C		65.8		dBFS
<b>SIGNAL-TO-NOISE-AND-DISTORTION(SINAD)RATIO</b>					
$f_{IN} = 9.7\text{MHz}$	25°C		77.3		dBFS
$f_{IN} = 16\text{MHz}$	25°C		76.9		dBFS
$f_{IN} = 64\text{MHz}$	25°C		75.1		dBFS
$f_{IN} = 128\text{MHz}$	25°C		71.6		dBFS
$f_{IN} = 201\text{MHz}$	25°C		68.5		dBFS
$f_{IN} = 301\text{MHz}$	25°C		65.6		dBFS

<b>EFFECTIVE NUMBER OF BITS(ENOB)</b>					
$f_{IN} = 9.7\text{MHz}$	25°C		12.5		Bits
$f_{IN} = 16\text{MHz}$	25°C		12.4		Bits
$f_{IN} = 64\text{MHz}$	25°C		12.2		Bits
$f_{IN} = 128\text{MHz}$	25°C		11.6		Bits
$f_{IN} = 201\text{MHz}$	25°C		11.1		Bits
$f_{IN} = 301\text{MHz}$	25°C		10.6		Bits
<b>SPURIOUS-FREE DYNAMIC RANGE(SFDR)</b>					
$f_{IN} = 9.7\text{MHz}$	25°C		97.6		dBc
$f_{IN} = 16\text{MHz}$	25°C		94.9		dBc
$f_{IN} = 64\text{MHz}$	25°C		92.5		dBc
$f_{IN} = 128\text{MHz}$	25°C		86.0		dBc
$f_{IN} = 201\text{MHz}$	25°C		77.5		dBc
$f_{IN} = 301\text{MHz}$	25°C		80.3		dBc
<b>WORST HARMONIC(SECOND OR THIRD)</b>					
$f_{IN} = 9.7\text{MHz}$	25°C		-97.6		dBc
$f_{IN} = 16\text{MHz}$	25°C		-94.9		dBc
$f_{IN} = 64\text{MHz}$	25°C		-92.5		dBc
$f_{IN} = 128\text{MHz}$	25°C		-86.0		dBc
$f_{IN} = 201\text{MHz}$	25°C		-77.5		dBc
$f_{IN} = 301\text{MHz}$	25°C		-80.3		dBc
<b>WPRST OTHER SPUR OR HARMONIC(EXCLUDING SECOND OR THIRD)</b>					
$f_{IN} = 9.7\text{MHz}$	25°C		-95		dBc
$f_{IN} = 16\text{MHz}$	25°C		-95		dBc
$f_{IN} = 64\text{MHz}$	25°C		-94		dBc
$f_{IN} = 128\text{MHz}$	25°C		-89		dBc
$f_{IN} = 201\text{MHz}$	25°C		-91		dBc
$f_{IN} = 301\text{MHz}$	25°C		-89		dBc
<b>TWO-TONE INTERMODULATION DISTORTION(IMD)-INPUT AMPLITUDE=-7.0dBFS</b>					
$f_{IN1}=70.5\text{MHz}, f_{IN1}=72.5\text{MHz}$	25°C		-89		dBc
<b>CROSSTALK</b>					
CROSSTALK <sup>2</sup>	25°C		-94		dB
CROSSTALK(OVERRANGE	25°C		-89		dB

CONDITION) <sup>3</sup>					
<b>ANALOG INPUT BANDWIDTH, FULL POWER</b>	25°C		650		MHz

1. When  $f_{IN} \geq 401\text{MHz}$  is tested, the test shall be conducted under the condition of  $A_{IN} = -5.0\text{dBFS}$ .
2. Crosstalk is measured at 70 MHz with  $-1.0\text{ dBFS}$  analog input on one channel and no input on the adjacent channel.
3. Over range condition is defined as the input being 3 dB above full scale.

### ● Digital Specifications

AVDD = 1.8 V, DRVDD = 1.8 V, SVDD = 1.8 V, 2.8 V p-p differential input, 1.4 V reference,  $A_{IN} = -1.0\text{ dBFS}$ , unless otherwise noted.

Table 5.

Parameter	Temperature	Min	Typ	Max	Unit
<b>CLOCK INPUT(CLK+, CLK-)</b>					
Logic Compliance			CMOS/LVDS/LVPECL		
Differential Input Voltage Range	Full	0.2		3.6	Vp-p
Input Voltage Range	Full	AGND-0.2		AVDD+0.2	V
Input Common-Mode Voltage	Full		0.9		V
Input Resistance(Differential)	25°C		15		kΩ
Input Capacitance	25°C		4		pF
<b>DSYNC INPUT(DSYNC+/ DSYNC-)</b>					
Logic Compliance	Full		LVDS		
Internal Common-Mode Bias	Full		0.9		V
Differential Input Voltage Range	Full	0.3		3.6	Vp-p
Input Voltage Range	Full	DGND		DVDD	V
Input Common-Mode Voltage Range	Full	0.9		1.4	V
High Level Input Current	Full	-5		+5	μA

Low Level Input Current	Full	-5		+5	μA
Input Capacitance	Full		1		pF
Input Resistance	Full	12	16	20	kΩ
<b>DSYSREF INPUT(DSYSREF+ / DSYSREF-)</b>					
Logic Compliance			LVDS		
Internal Common-Mode Bias	Full		0.9		V
Differential Input Voltage Range	Full	0.3		3.6	Vp-p
Input Voltage Range	Full	DGND		DVDD	V
Input Common-Mode Voltage Range	Full	0.9		1.4	V
High Level Input Current	Full	-5		+5	μA
Low Level Input Current	Full	-5		+5	μA
Input Capacitance	Full		4		pF
Input Resistance	Full	8	10	12	kΩ
<b>LOGIC INPUT(PDWN、SYNC、SCLK)</b>					
Logic 1 Voltage Range	Full	1.2		AVDD+0.2	V
Logic 0 Voltage Range	Full	0		0.8	V
Input Resistance	25°C		30		kΩ
Input Capacitance	25°C		2		pF
<b>LOGIC INPUT(CSB)</b>					
Logic 1 Voltage Range	25°C	1.2		AVDD+0.2	V
Logic 0 Voltage Range	25°C	0		0.8	V
Input Resistance	25°C		26		kΩ
Input Capacitance	25°C		2		pF
<b>LOGIC INPUT(SDIO)</b>					
Logic 1 Voltage Range	25°C	1.2		AVDD+0.2	V
Logic 0 Voltage Range	25°C	0		0.8	V
Input Resistance	25°C		26		kΩ
Input Capacitance	25°C		5		pF
<b>DIGITAL OUTPUTS (SERDOUTx+、SERDOUTx-)</b>					

Logic Compliance	Full		CML400		
Differential Output Voltage( $V_{OD}$ )	Full	400	600	750	mV
Output Offset Voltage( $V_{OS}$ )	Full	0.75	DRVDD/2	1.05	V

### ● Switching Specifications

AVDD = 1.8 V, DRVDD = 1.8 V, 2.8 V p-p differential input, 1.4 V reference,  $A_{IN} = -1.0$  dBFS, unless otherwise noted.

Table6.

Parameter	Temperature	Min	Typ	Max	Unit
<b>CLOCK</b>					
Input Clock Rate	Full	40		1000	MHz
Conversion Rate		40		125	MSPS
Clock Pulse Width High( $t_{EH}$ )			4		ns
Clock Pulse Width Low( $t_{EL}$ )			4	1.4	ns
SYNC Setup Time to Clock				-0.4	ns
SYNC Hold Time to Clock			370	600	ns
DSYSREF Setup Time to Clock( $t_{REFS}$ ) <sup>4</sup>			-92	0	ps
DSYSREF Hold Time to Clock( $t_{REFH}$ ) <sup>4</sup>					ps
<b>DATA OUTPUT PARAMETERS</b>					
Data Output Period or Unit Interval(UI)	Full		$L/(20 \times M \times fS)$		秒
Data Output Duty Cycle	25°C		50		%
Data Valid Time	25°C		0.81		UI
PLL Lock Time( $t_{LOCK}$ )	25°C		25		$\mu s$
Wake-Up Time					
Standby	25°C		250		ns
ADC(Power-Down)	25°C		375		$\mu s$
Output(Power-Down)	25°C		50		$\mu s$
DSYNC Falling Edge to First K.28 Characters	Full	4			Multiframes

CGS Phase K.28 Characters	Full	1			Multiframes
Duration					
Pipeline Delay					
JESD204B M4、L1 Mode(Latency)	Full		23		Cycle 7
JESD204B M4、L2 Mode(Latency)	Full		29		Cycle 7
JESD204B M4、L4 Mode(Latency)	Full		44		Cycle 7
Data Rate per Lane	Full			6.4	Gbps
Deterministic Jitter(D <sub>j</sub> )					
At 6.4 Gbps	Full		8		Ps
Random Jitter(R <sub>j</sub> )					
At 6.4 Gbps	Full		1.25		ps rms
Output Rise Time/Fall Time	Full		50		ps
Differential Termination Resistance	25°C		100		Ω
<b>APERTURE</b>					
Aperture Delay(t <sub>A</sub> )	25°C		1		
Aperture Uncertainty(Jitter, t <sub>j</sub> )	25°C		135		
Out of Range Recovery Time	25°C		1		

## ● Timing Specifications

Table 7.

Parameter	Description	Limit	Unit
<b>SPI TIMING REQUIREMENTS See Figure 70</b>			
t <sub>DS</sub>	Setup time between the data and the rising edge of SCLK	2	ns(min)
t <sub>DH</sub>	Hold time between the data and the rising edge of SCLK	2	ns(min)
t <sub>CLK</sub>	Period of the SCLK	40	ns(min)
t <sub>S</sub>	Setup time between CSB and SCLK	2	ns(min)
t <sub>H</sub>	Hold time between CSB and SCLK	2	ns(min)
t <sub>HIGH</sub>	SCLK pulse width high	10	ns(min)
t <sub>LOW</sub>	SCLK pulse width low	10	ns(min)
t <sub>EN_SDIO</sub>	Time required for the SDIO pin to switch from an input to an output relative to the SCLK falling edge	10	ns(min)
t <sub>DIS_SDIO</sub>	Time required for the SDIO pin to switch from an output to an input relative to the SCLK rising edge	10	ns(min)

## Timing Diagrams

Refer to the Memory Map Register Table section for SPI register settings.

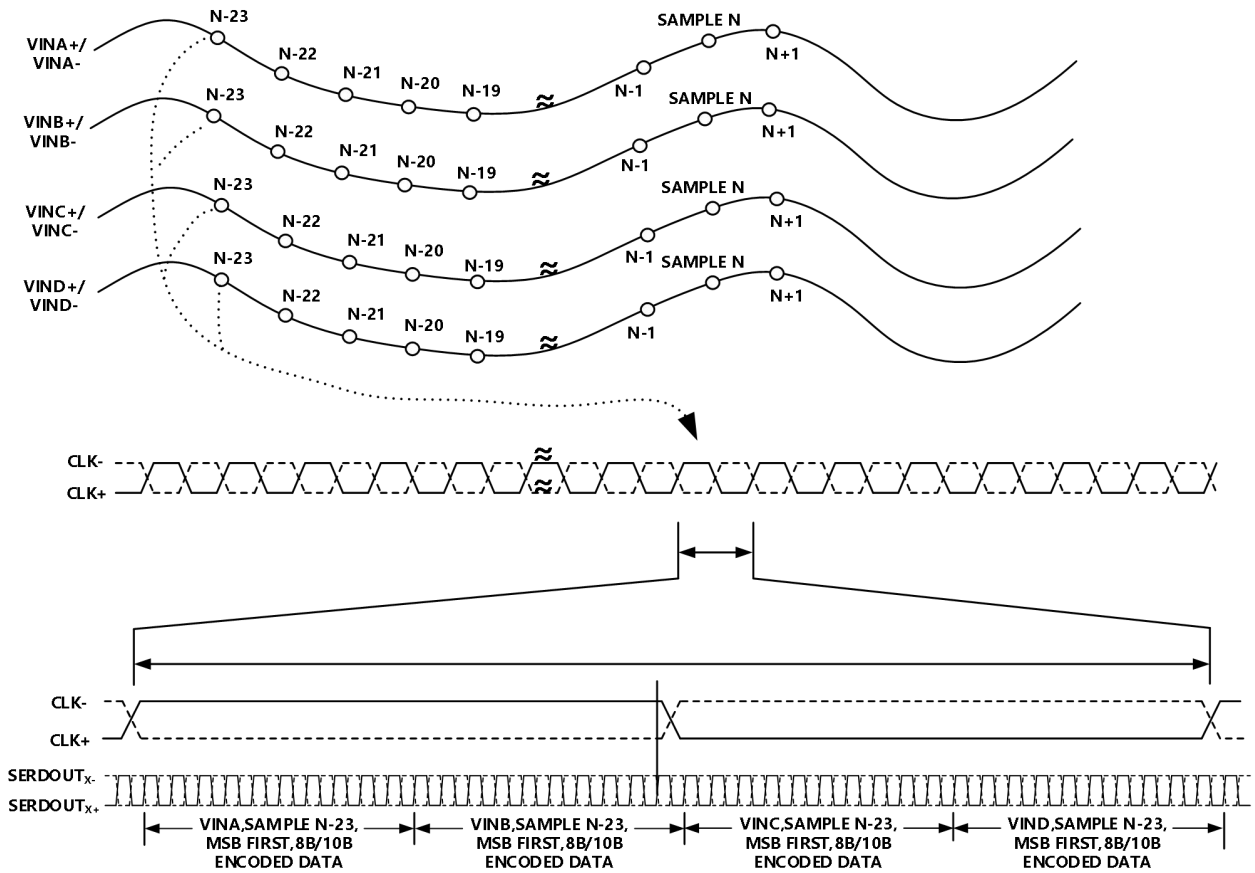

Figure 2. Data Output Timing, M=4, L=1

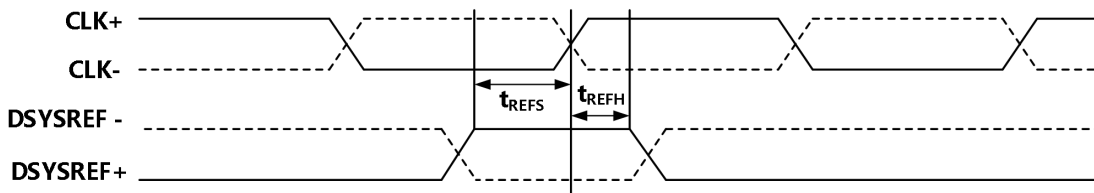

Figure 3. SYSREF± Setup and Hold Timing (Clock Divider = 1)

## Absolute Maximum Ratings

Parameter	Rating
Electrical	-0.3 V to +2.0 V
AVDD to AGND	-0.3 V to +2.0 V
DRVDD to AGND	-0.3 V to +2.0 V
DVDD to DVSS	-0.3 V to +2.0 V
SVDD to AGND	-0.3 V to +2.0 V
Digital Outputs to AGND	-0.3 V to +2.0 V
CLK+, CLK- to AGND	-0.3 V to +2.0 V
VINx+, VINx- to AGND	-0.3 V to +2.0 V
DSYSREF+, DSYSREF- to AGND DSYNC-, DSYNC+ to AGND	-0.3 V to +2.0 V
SCLK, SDIO, CSB, PDWN to AGND SYNC to AGND	-0.3 V to +3.9 V
RBIAS to AGND	-0.3 V to +2.0 V
VCM, VREF, SENSE to AGND	
Environmental	
Operating Temperature Range (Ambient)	-40°C to +85°C
Maximum Junction Temperature	150°C
Lead Temperature (Soldering, 10 sec)	300°C
Storage Temperature Range (Ambient)	-65°C to +150°C

Stresses at or above those listed under Absolute Maximum Ratings may cause permanent damage to the product. This is a stress rating only; functional operation of the product at these or any other conditions above those indicated in the operational section of this specification is not implied. Operation beyond the maximum operating conditions for extended periods may affect product reliability.

**THERMAL RESISTANCE:**  $\theta_{JA}$  is for a 4-layer printed circuit board (PCB) with solid ground plane (simulated). The exposed pad is soldered to the PCB ground.

Package Type	Air Flow Velocity(m/s)	$\theta_{JA}$ (°C/W)	$\theta_{JB}$ (°C/W) <sup>1</sup>	$\theta_{JC}$ Top (°C/W) <sup>1</sup>	$\theta_{JC}$ Bottom(°C/W) <sup>1</sup>
56-Lead LFCSP, 8mm×8mm	0	22.4	7.7	7.42	2.29
	1	19.0	N/A	N/A	N/A
	2.5	17.6	N/A	N/A	N/A



## Pin Configuration and Function Descriptions

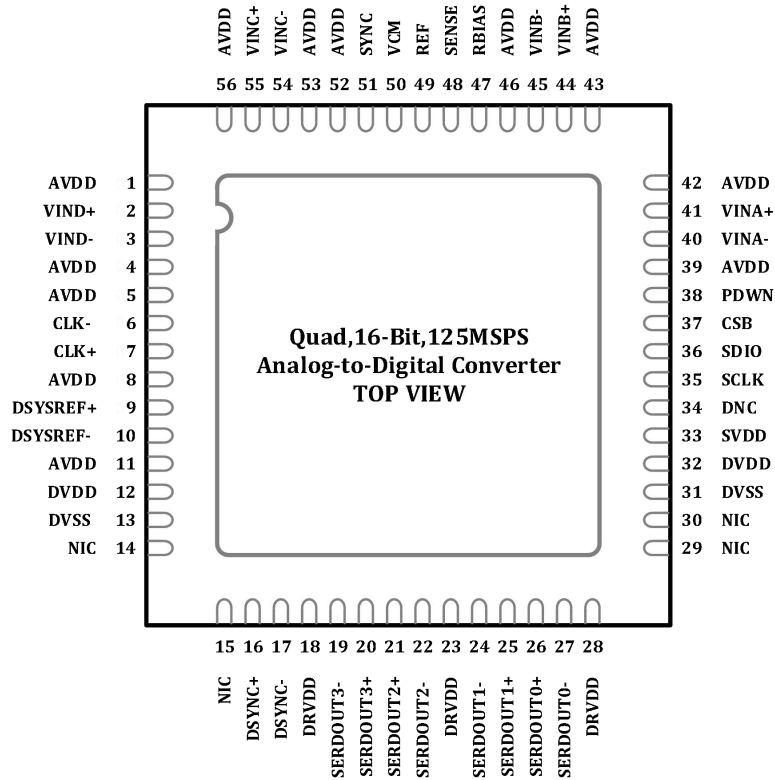

Figure 4. Pin Configuration, Top View

The INL and DNL test curves are shown in Figure 3. The FFT with input analog input frequency of 100MHz and sampling rate of 250MSPS is shown in Figure 4. The FFT with input analog input frequency of 170MHz and sampling rate of 250MSPS is shown in Figure 5. The FFT with input analog input frequency of 230MHz and sampling rate of 250MSPS is shown in Figure 6. The FFT with input analog input frequency of 300MHz and sampling rate of 250MSPS is shown in Figure 7. The bandwidth test is shown in Figure 8.

Table 10. Pin Function Descriptions

Pin No.	Mnemonic	Description
0	AGND, Exposed Pad	
1,4,5,8,11,39,42,43,46,52,53,56	AVDD	1.8 V Analog Supply Pins.
2	VIND+	ADC D Analog Input True.
3	VIND-	ADC D Analog Input Complement.
6,7	CLK-,CLK+	Differential Encode Clock. PECL, LVDS, or 1.8 V CMOS

		inputs.
9	DSYSREF+	Active High JESD204B LVDS SYSREF Input True.
10	DSYSREF-	Active High JESD204B LVDS SYSREF Input Complement.
12,32	DVDD	Digital Supply.
13,31	DVSS	Digital Ground.
14,15,29,30	NIC	Not Internally Connected. Can be connected to ground if desired.
16	DSYNC+	Active Low JESD204B LVDS SYNC Input True.
17	DSYNC-	Active Low JESD204B LVDS SYNC Input Complement.
18,23,28	DRVDD	Digital Output Driver Supply.
19	SEROUT3-	Lane 3 Digital Output Complement.
20	SEROUT3+	Lane 3 Digital Output True.
21	SEROUT2+	Lane 2 Digital Output True.
22	SEROUT2-	Lane 2 Digital Output Complement.
24	SEROUT1-	Lane 1 Digital Output Complement.
25	SEROUT1+	Lane 1 Digital Output True.
26	SEROUT0+	Lane 0 Digital Output True.
27	SEROUT0-	Lane 0 Digital Output Complement.
33	SVDD	SPI Supply Pin.
34	DNC	Do Not Connect. Do not connect to this pin.
35	SCLK	SPI Clock Input.
36	SDIO	SPI Data Input and Output, Bidirectional.
37	CSB	SPI Chip Select Bar.Active low enable;30kΩ internal pull-up resistor.
38	PDWN	Digital Input.This pin has a 30kΩ internal pill-down resistor.PDWN high=power-down device and PDWN low=run device(normal operation)
40	VINA-	ADC A Analog Input Complement.
41	VINA+	ADC A Analog Input True.
44	VINB+	ADC B Analog Input True.
45	VINB-	ADC B Analog Input Complement.
47	RBIAS	Sets Analog Current Bias.This pin connects a 10kΩ(1%

		tolerance)resistor to ground.
48	SENSE	Reference Mode Selection.
49	VREF	Voltage Reference Input and Output.
50	VCM	Analog Input Common-Mode Voltage.
51	SYNC	Digital Input. Synchronous input to clock divider.
54	VINC-	ADC C Analog Input Complement.
55	VINC+	ADC C Analog Input True.

## Typical Performance Characteristics

●  $V_{REF} = 1.4V$

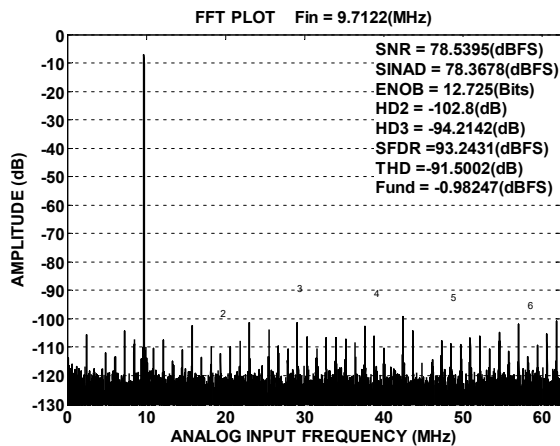

Figure 5. Single-Tone 32k FFT with  $f_{IN} = 9.7\text{ MHz}$ ,  $f_s = 125\text{ MSPS}$

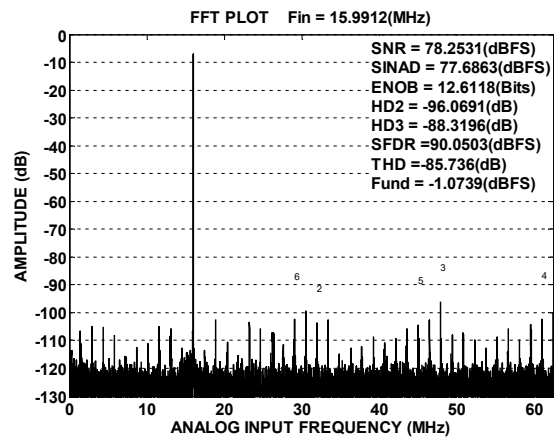

Figure 6. Single-Tone 32k FFT with  $f_{IN} = 16.3\text{ MHz}$ ,  $f_s = 125\text{ MSPS}$

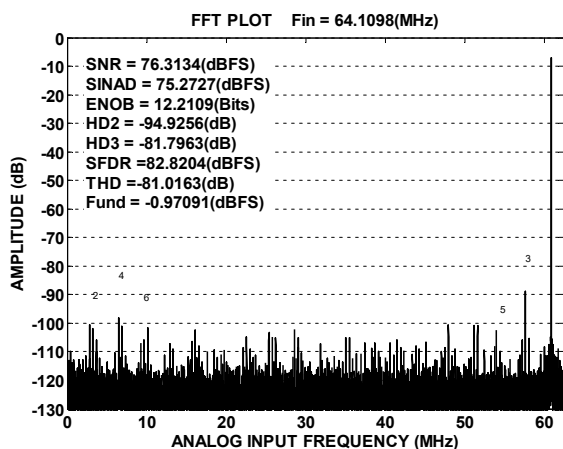

Figure 7. Single-Tone 32k ( $f_{IN} = 64\text{ MHz}$ ,  $f_s = 125\text{ MSPS}$ )

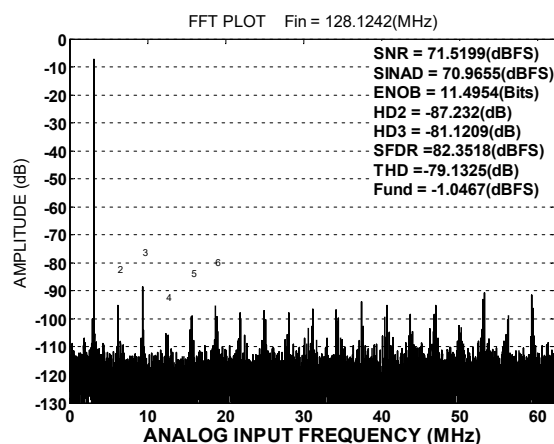

Figure 8. Single-Tone 32k ( $f_{IN} = 128\text{ MHz}$ ,  $f_s = 125\text{ MSPS}$ )

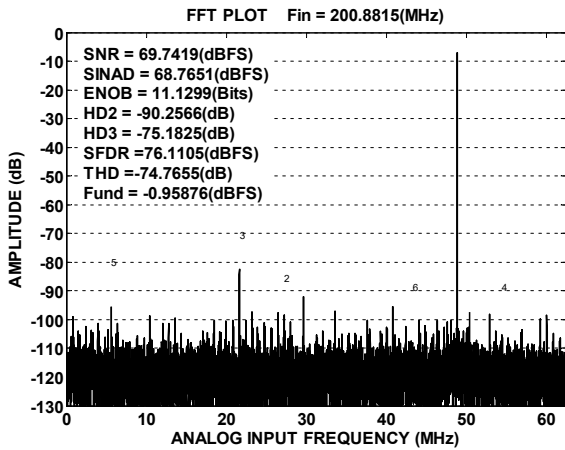

Figure9.Single-Tone 32K( $f_{IN}=201\text{MHz}$ ,  $f_s=125\text{MSPS}$ )

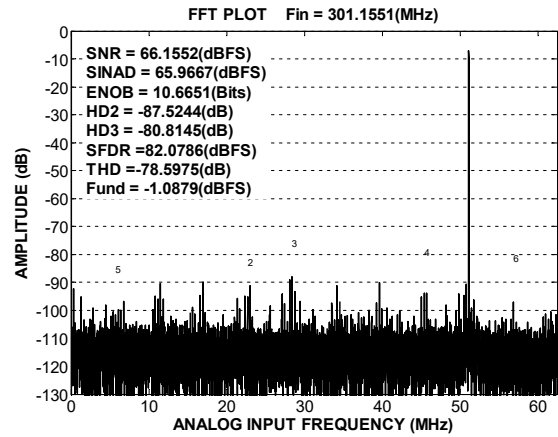

Figure10.Single-Tone32K( $f_{IN}=301\text{MHz}$ ,  $f_s=125\text{MSPS}$ )

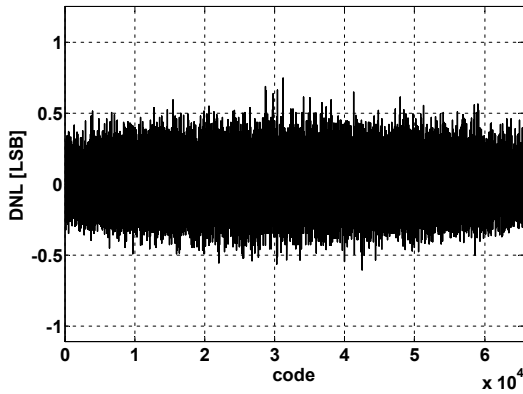

Figure11.Differential Nonlinearity (DNL)( $f_{IN}=9.7\text{MHz}$ ,  $f_s=125\text{MSPS}$ )

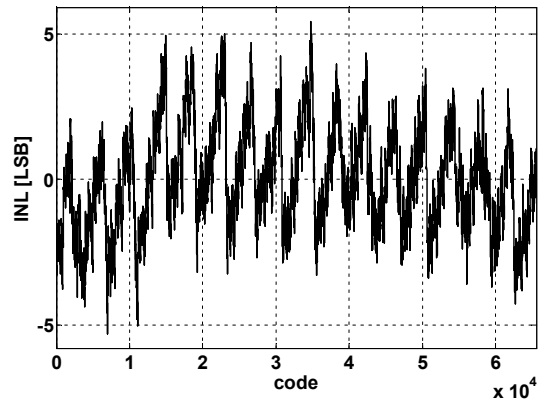

Figure12.Integral Nonlinearity (INL)( $f_{IN}=9.7\text{MHz}$ ,  $f_s=125\text{MSPS}$ )

●  $V_{REF} = 1.0 \text{ V}$

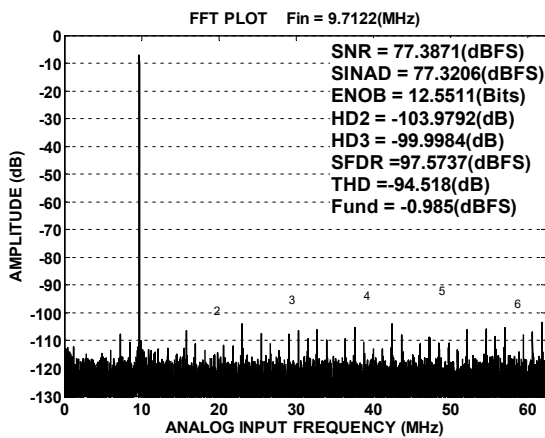

Figure13.Single-Tone 32K( $f_{IN}=9.7\text{MHz}$ ,  $f_s=125\text{MSPS}$ )

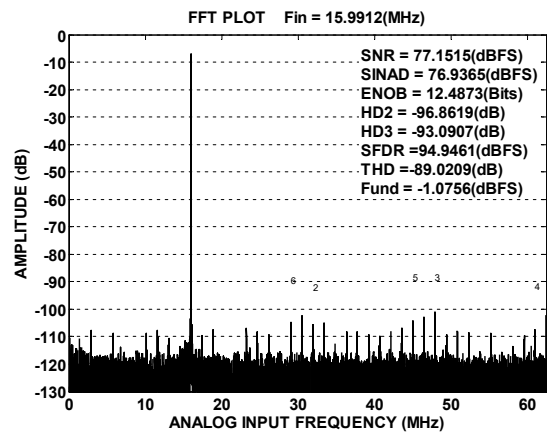

Figure14.Single-Tone 32K( $f_{IN}=16\text{MHz}$ ,  $f_s=125\text{MSPS}$ )

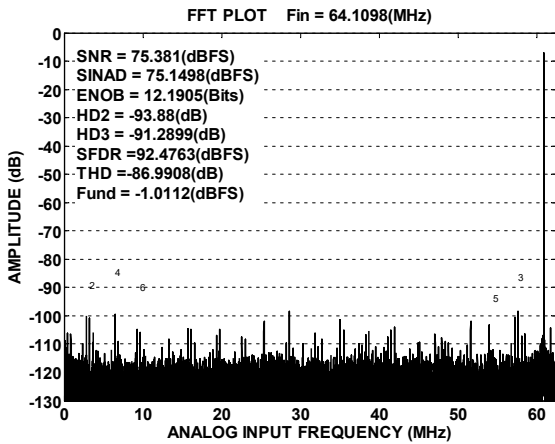

Figure15.Single-Tone 32K( $f_{IN}=64\text{MHz}$ ,  $f_s=125\text{MSPS}$ )

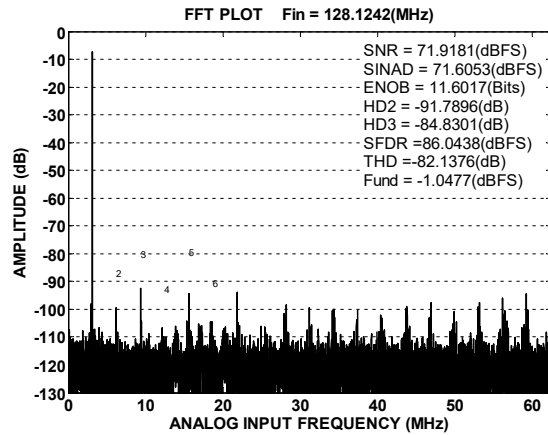

Figure16.Single-Tone 32K( $f_{IN}=128\text{MHz}$ ,  $f_s=125\text{MSPS}$ )

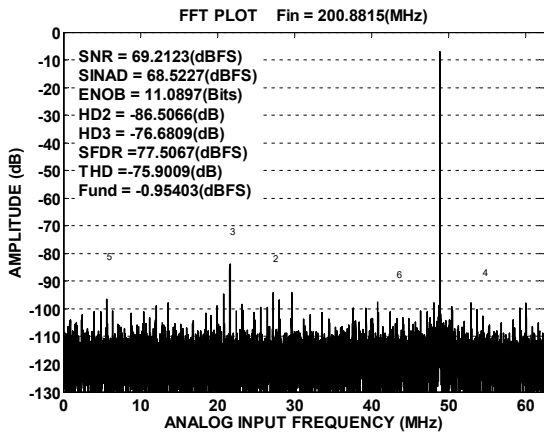

Figure17.Single-Tone 32K( $f_{IN}=201\text{MHz}$ ,  $f_s=125\text{MSPS}$ )

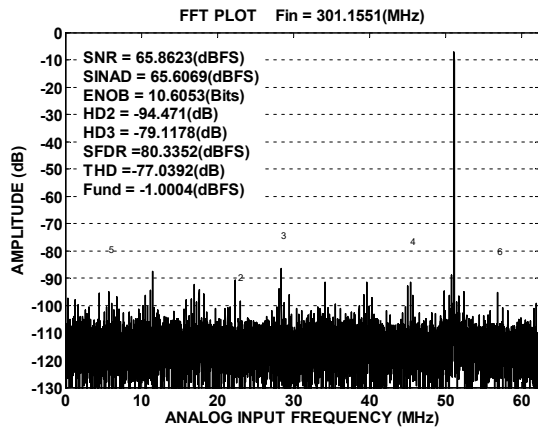

Figure18.Single-Tone 32K( $f_{IN}=301\text{MHz}$ ,  $f_s=125\text{MSPS}$ )

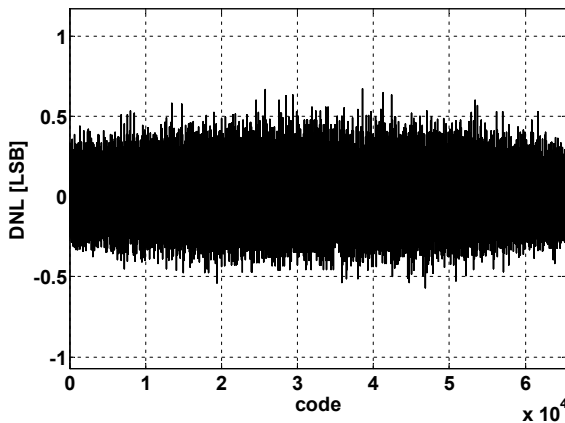

Figure19.Differential Nonlinearity (DNL)( $f_{IN}=10\text{MHz}$ ,  $f_s=125\text{MSPS}$ )

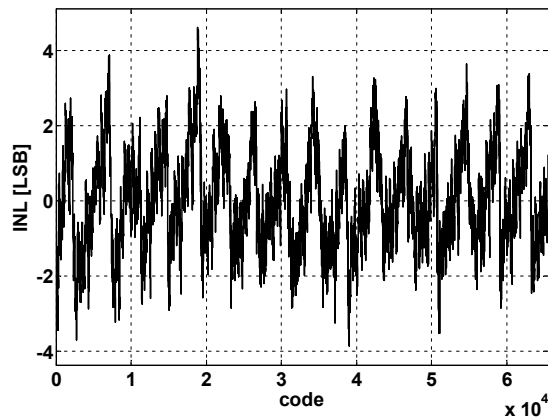

Figure20.Integral Nonlinearity (INL)( $f_{IN}=10\text{MHz}$ ,  $f_s=125\text{MSPS}$ )

## Equivalent Circuits

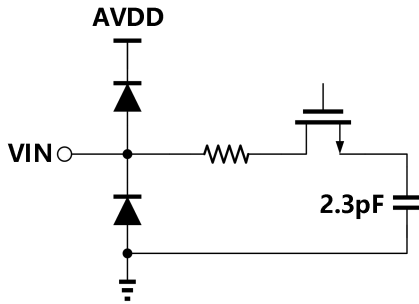

Figure 21. Equivalent Analog Input Circuit

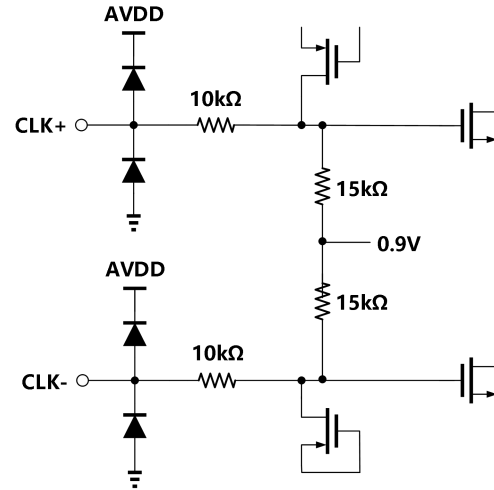

Figure 22. Equivalent CLOCK Input Circuit

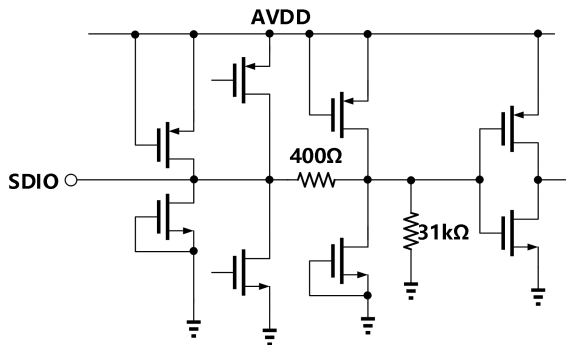

Figure 23. Equivalent SDIO Input Circuit

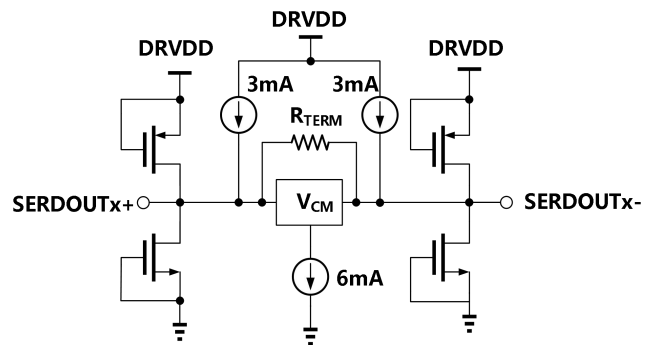

Figure 24. Equivalent SERDOUT± Circuit

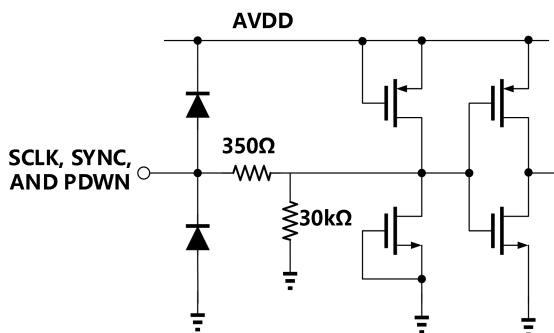

Figure 25. Equivalent SCLK, SYNC, PDWN Circuit

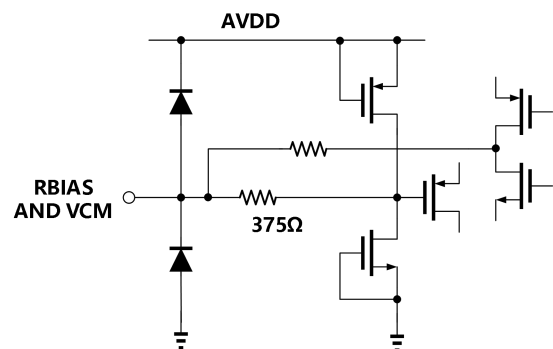

Figure 26. Equivalent RBIAS, VCM Circuit

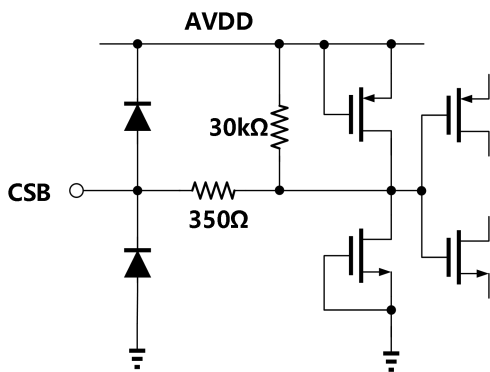

Figure27.Equivalent CSB Input Circuit

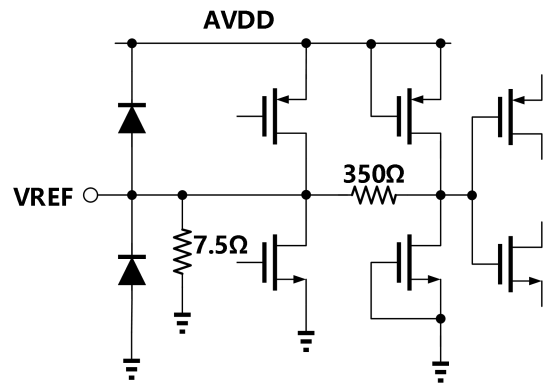

Figure28.Equivalent VREF Input Circuit

## Theory of Operation

The CBM96AD56-125 is a multistage, pipelined ADC. Each stage provides sufficient overlap to correct for flash errors in the preceding stage. The quantized outputs from each stage are combined into a final 16-bit result in the digital correction logic. The serializer transmits this converted data in a 16-bit output. The pipelined architecture permits the first stage to operate with a new input sample while the remaining stages operate with the preceding samples. Sampling occurs on the rising edge of the clock.

Each stage of the pipeline, excluding the last, consists of a low resolution flash ADC connected to a switched-capacitor DAC and an interstage residue amplifier (for example, a multiplying digital-to-analog converter [MDAC]). The residue amplifier magnifies the difference between the reconstructed DAC output and the flash input for the next stage in the pipeline. One bit of redundancy is used in each stage to facilitate digital correction of flash errors. The last stage simply consists of a flash ADC.

The output staging block aligns the data, corrects errors, and passes the data to the output buffers. The data is then serialized and aligned to the frame and data clocks.

### ● Analog Input Considerations

The analog input to the CBM96AD56-125 is a differential switched- capacitor circuit designed for processing differential input signals. This circuit can support a wide common-mode range while maintaining excellent performance. By using an input common-mode voltage of midsupply, users can minimize signal-dependent errors and achieve optimum performance.

The clock signal alternately switches the input circuit between sample mode and hold mode (see Figure 29). When the input circuit is switched to sample mode, the signal source must be capable of charging the sample capacitors and settling within one-half of a clock cycle. A small resistor in series with each input can help reduce the peak transient current injected from the output stage

of the driving source. In addition, low Q inductors or ferrite beads can be placed on each leg of the input to reduce high differential capacitance at the analog inputs and therefore achieve the maximum bandwidth of the ADC. Such use of low Q inductors or ferrite beads is required when driving the converter front end at high IF frequencies. Either a differential capacitor or two single-ended capacitors can be placed on the inputs to provide a matching passive network. This ultimately creates a low-pass filter at the input to limit unwanted broadband noise. See the AN-742 Application Note, the AN-827 Application Note, and the Analog Dialogue article “Transformer-Coupled Front-End for Wideband A/D Converters” for more information. In general, the precise values depend on the application.

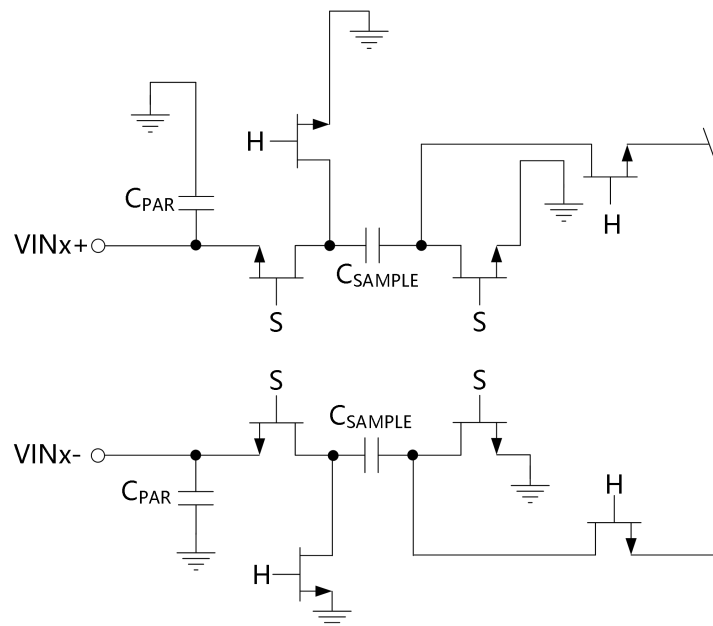

Figure 29. Switched-Capacitor Input Circuit

### ● Input common mode level

The analog inputs of the CBM96AD56-125 are not internally dc-biased. Therefore, in ac-coupled applications, the user must provide this bias externally. Setting the device so that  $V_{CM} = AV_{DD}/2$  is recommended for optimum performance, but the device can function over a wider  $V_{CM}$  range with reasonable performance, as shown in Figure 30 and Figure 31.



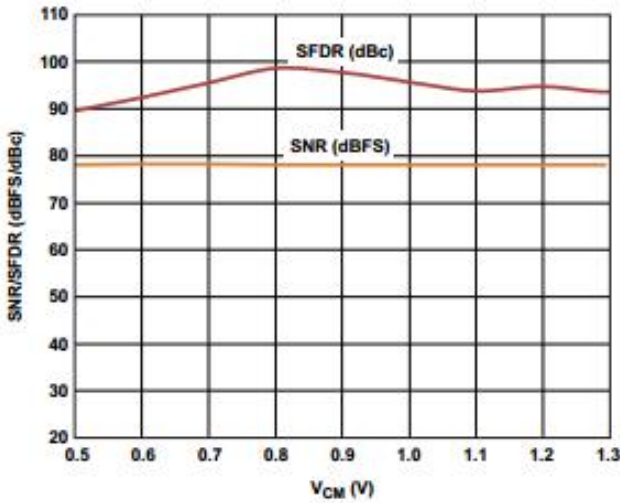

Figure 30. SNR/SFDR vs. Common-Mode Voltage (V<sub>CM</sub>),  
(f<sub>IN</sub>=9.7MHz, f<sub>SAMPLE</sub>=125MSPS, V<sub>REF</sub>=1.0V)

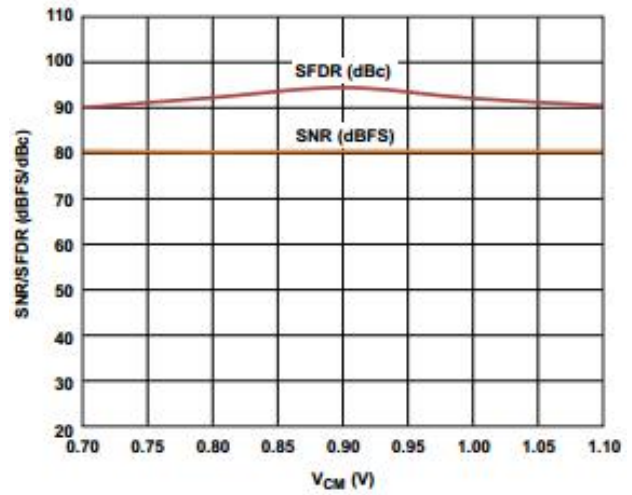

Figure 31. SNR/SFDR vs. Common-Mode Voltage (V<sub>CM</sub>),  
(f<sub>IN</sub>=9.7MHz, f<sub>SAMPLE</sub>=125MSPS, V<sub>REF</sub>=1.4V)

An on-chip, common-mode voltage reference is included in the design and is available from the VCM pin. Bypass the VCM pin to ground with a 0.1 μF capacitor, as described in the Applications Information section. Maximum SNR performance is achieved by setting the ADC to the largest span in a differential configuration. In the case of the CBM96AD56-125, the input span is dependent on the reference voltage .

● **Differential input configuration**

There are several ways to drive the CBM96AD56-125 either actively or passively. However, optimum performance is achieved by driving the analog inputs differentially. Using a differential double balun configuration to drive the CBM96AD56-125 provides excellent performance and a flexible interface to the ADC for baseband applications (see Figure 32).

For applications where SNR is a key parameter, differential transformer coupling is the recommended input configuration (see Figure 33) because the noise performance of most amplifiers is not adequate to achieve the true performance of the CBM96AD56-125. Regardless of the configuration, the value of the shunt capacitor, C, is dependent on the input frequency and may need to be reduced or removed. It is not recommended to drive the CBM96AD56-125 inputs single-ended.

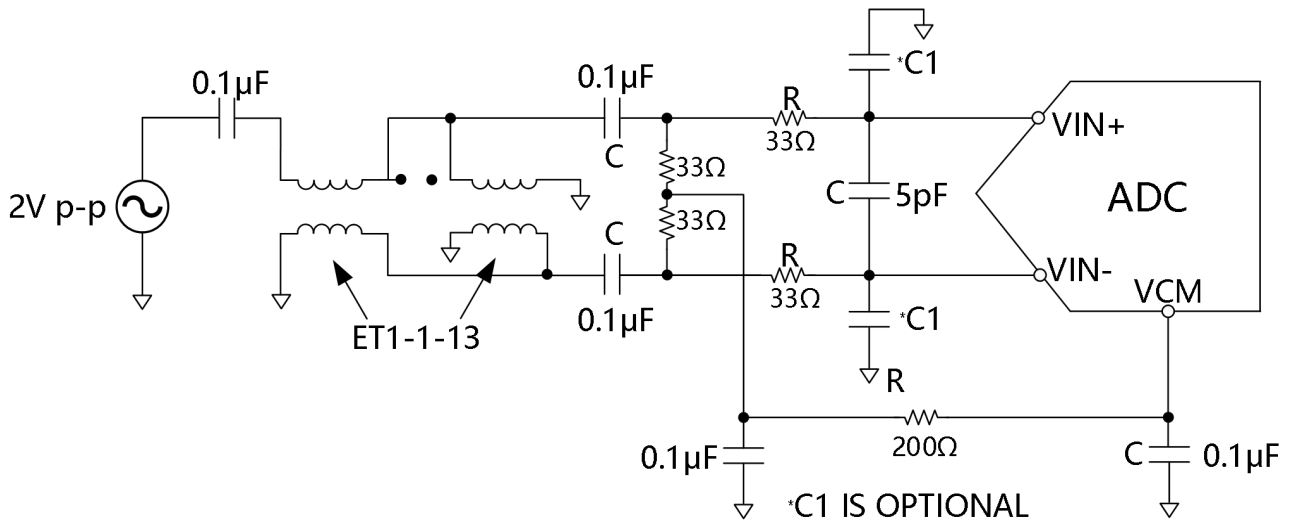

Figure 32. Differential Double Balun Input Configuration for Baseband Applications

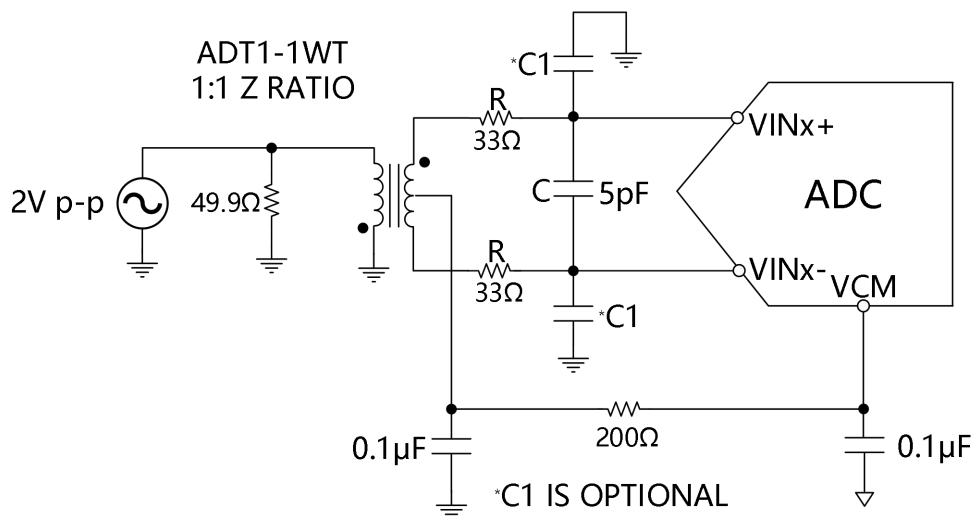

Figure 33. Differential Transformer-Coupled Configuration for Baseband Applications

### ● Voltage Reference

A stable and accurate voltage reference is built into the CBM96AD56-125. VREF can be configured using the internal 1.0 V reference, using an externally applied 1.0 V to 1.4 V reference voltage, or using an external resistor divider applied to the internal reference to produce a user-selectable reference voltage. The reference modes are described in the Internal Reference Connection section and the External Reference Operation section. Externally bypass the VREF pin to ground with a low equivalent series resistance (ESR), 1.0  $\mu$ F capacitor in parallel with a low ESR, 0.1  $\mu$ F ceramic capacitor.

A comparator within the CBM96AD56-125 detects the potential at the SENSE pin and configures the reference for one of three possible modes, which are summarized in Table 11. If SENSE is grounded, the reference amplifier switch is connected to the internal resistor divider (see Figure 34), setting the voltage at the VREF pin, VREF, to 1.0 V. If SENSE is connected to an external resistor divider (see Figure 35), VREF is defined as:

$$V_{ref} = 0.5 \times (1 + R2/R1)$$

Where,  $7\text{ k}\Omega \leq (R1 + R2) \leq 10\text{ k}\Omega$

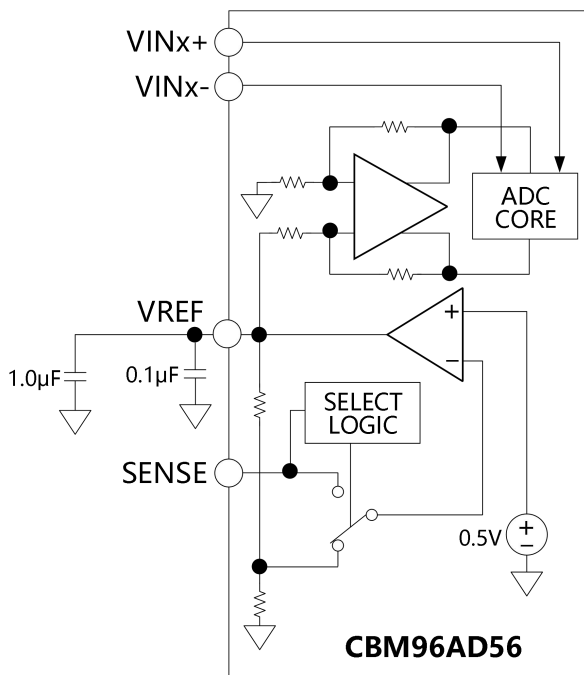

Figure 34.1.0 V Internal Reference Configuration

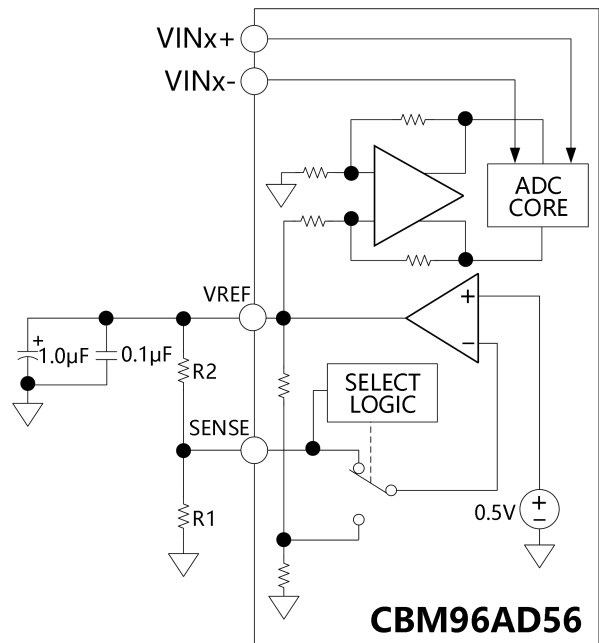

Figure 35. Programmable Internal Reference Configuration

If the internal reference of the CBM96AD56-125 drives multiple converters to improve gain matching, the loading of the reference by the other converters must be considered. Figure 36 and Figure 37 show how the internal reference voltage is affected by loading.

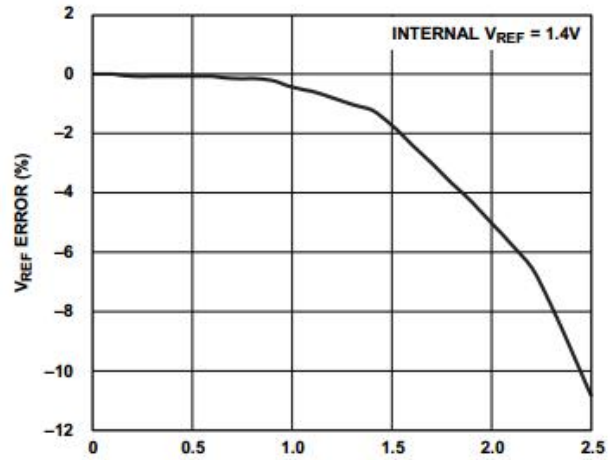
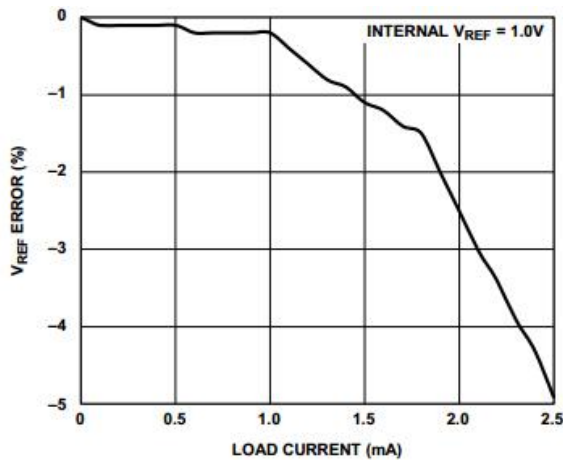

Figure 36. V<sub>REF</sub> Error (Internal V<sub>REF</sub> = 1.0 V) vs. Load Current      Figure 37. V<sub>REF</sub> Error (Internal V<sub>REF</sub> = 1.4 V) vs. Load Current

● External reference voltage

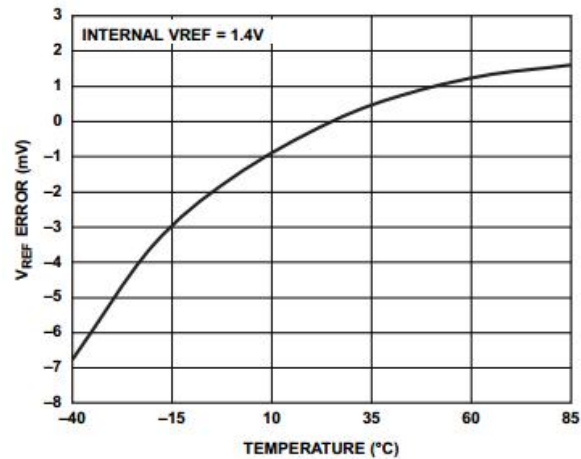
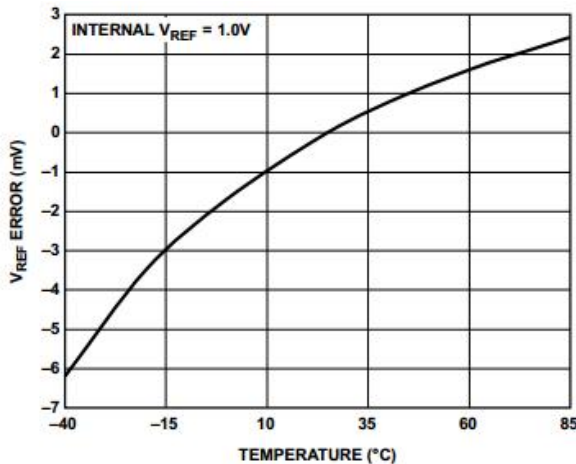

Figure 38. V<sub>REF</sub> Error vs. Temperature, Typical V<sub>REF</sub> = 1.0 V Drift      Figure 39. V<sub>REF</sub> Error vs. Temperature, Typical V<sub>REF</sub> = 1.4 V Drift

When the SENSE pin is tied to AVDD, the internal reference is disabled, allowing the use of an external reference. An internal reference buffer loads the external reference with an equivalent 7.5 kΩ load. The internal buffer generates the positive and negative full-scale references for the ADC core. It is not recommended to leave the SENSE pin floating.

● Clock Input Considerations

For optimum performance, clock the CBM96AD56-125 sample clock inputs, CLK+ and CLK-, with a differential signal. The signal is typically ac-coupled into the CLK+ and CLK- pins via a transformer or capacitors. These pins are biased internally and require no external bias.

● Clock input options

The CBM96AD56-125 has a flexible clock input structure. The clock input can be a CMOS, LVDS, LVPECL, or sine wave signal. Regardless of the type of signal used, clock source jitter is of the most concern, as described in the Jitter Considerations section.

Figure 10 and Figure 11 show two preferred methods for clocking the CBM96AD56-125 (at clock rates up to 1 GHz prior to internal clock divider). A low jitter clock source is converted from a single-ended signal to a differential signal using either a radio frequency (RF) transformer or an RF balun.

The RF balun configuration is recommended for clock frequencies between 125 MHz and 1 GHz, and the RF transformer configuration is recommended for clock frequencies from 40 MHz to 200 MHz. The Schottky diodes, across the transformer/balun secondary winding, limit clock excursions into the CBM96AD56-125 to approximately 0.8 V p-p differential (see Figure 40 and Figure 41). This limit helps prevent the large voltage swings of the clock from feeding through to other portions of the CBM96AD56-125 while preserving the fast rise and fall times of the signal that are critical to achieving low jitter performance. However, the diode capacitance has an effect on frequencies above 500 MHz. Take care in choosing the appropriate signal limiting diode.

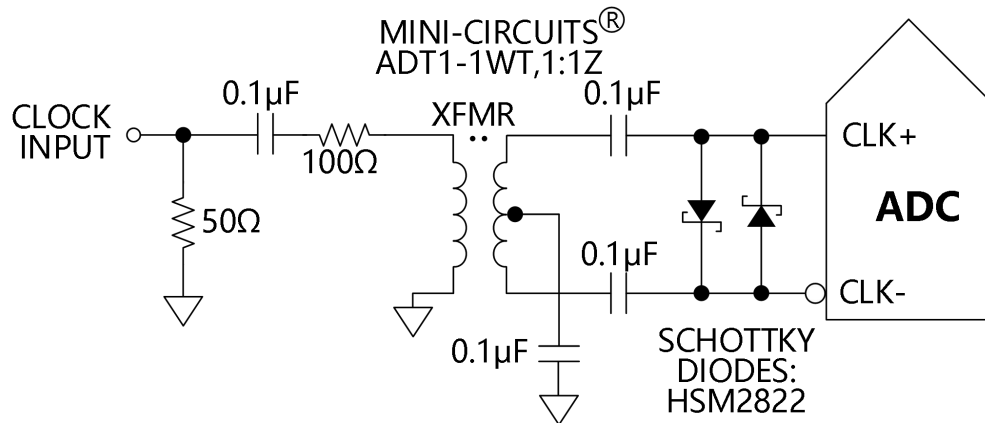

Figure 40. Transformer-Coupled Differential Clock (Up to 200 MHz)

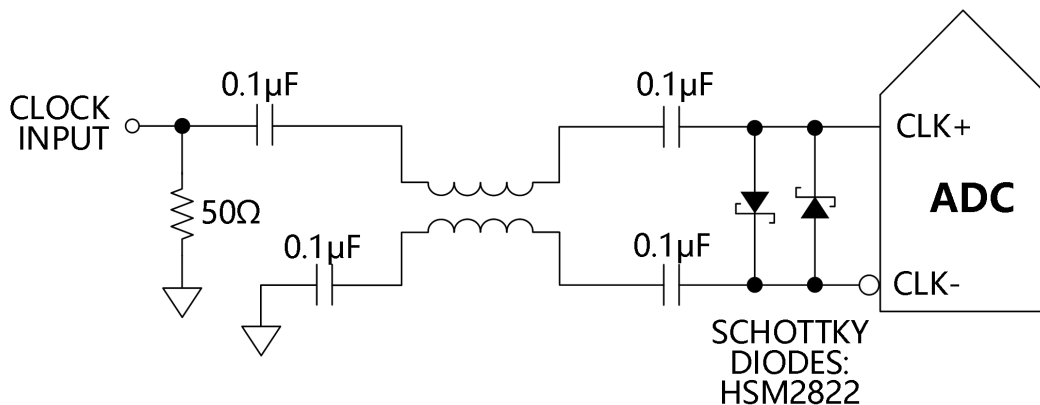

Figure 41. Balun-Coupled Differential Clock (Up to 1 GHz)

If a low jitter clock source is not available, another option is to ac-couple a differential PECL signal to the sample clock input pins, as shown in Figure 42. The AD9510/AD9511/AD9512/AD9513/AD9514/AD9515/AD9516/AD9517 clock drivers offer excellent jitter performance.

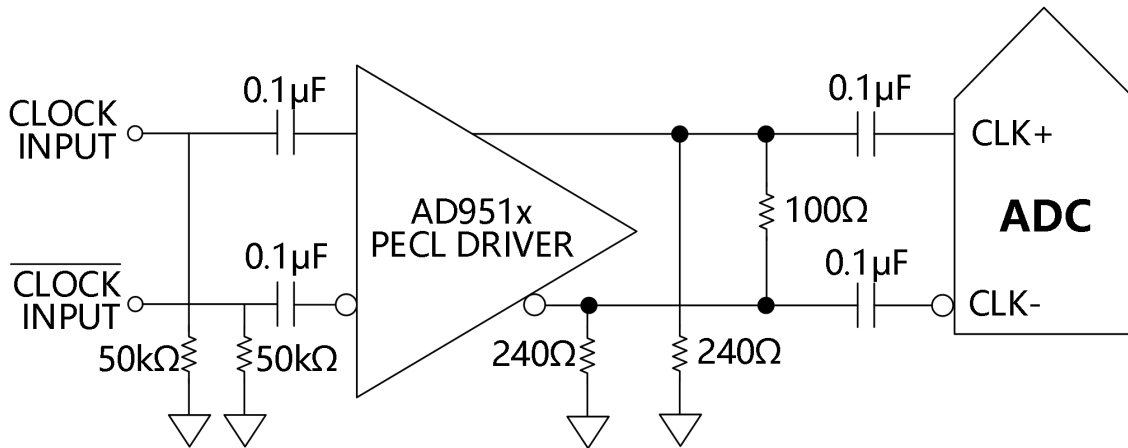

Figure 42. Differential PECL Sample Clock (Up to 1 GHz)

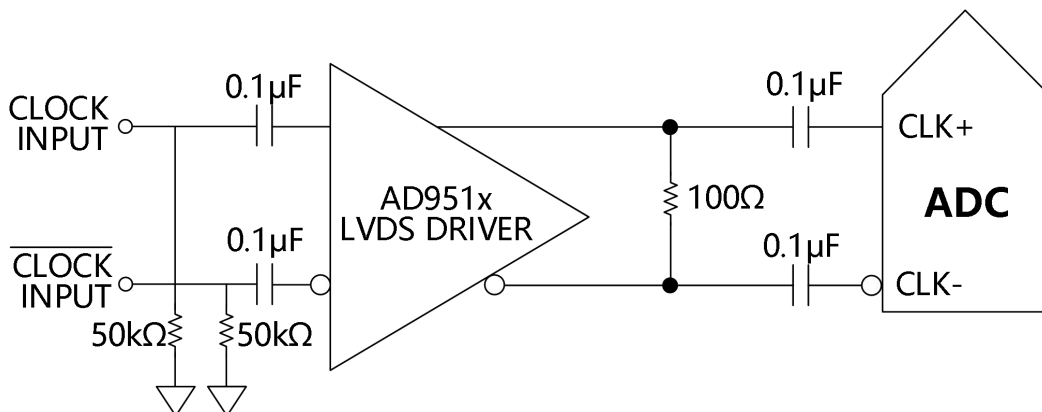

Figure 43. Differential LVDS Sample Clock (Up to 1 GHz)

### ● Input clock divider

The CBM96AD56-125 contains an input clock divider with the ability to divide the input clock by integer values from 1 to 8.

The CBM96AD56-125 clock divider can be synchronized using the external SYNC input. Bit 0 and Bit 1 of Register 0x109 allow the clock divider to resynchronize on every SYNC signal or only on the first SYNC signal after the register is written. A valid SYNC causes the clock divider to reset to the initial state. This synchronization feature allows multiple devices to have the clock dividers aligned to guarantee simultaneous input sampling.

Alternatively,  $SYSREF_{\pm}$  can reset the clock divider by setting Register 0x109 Bit[7]. In this case SYNC is disabled.

### ● Clock duty cycle

Typical high speed ADCs use both clock edges to generate a variety of internal timing signals and, as a result, can be sensitive to the clock duty cycle. Commonly, a  $\pm 5\%$  tolerance is required on the clock duty cycle to maintain dynamic performance characteristics.

The CBM96AD56-125 contains a duty cycle stabilizer (DCS) that retimes the nonsampling (falling) edge, providing an internal clock signal with a nominal 50% duty cycle. This feature minimizes performance degradation in cases where the clock input duty cycle deviates more than the specified  $\pm 5\%$  from the nominal 50% duty cycle. Enabling the DCS function can significantly improve noise and distortion performance for clock input duty cycles ranging from 30% to 45% and from 55% to 70%.

Jitter in the rising edge of the input is still of concern and is not easily reduced by the internal stabilization circuit. The loop has a time constant associated with it that must be considered in applications in which the clock rate can change dynamically. A wait time of 1.5  $\mu\text{s}$  to 5  $\mu\text{s}$  is required after a dynamic clock frequency increase or decrease before the DCS loop is relocked to the input signal.

### ● Jitter considerations

High speed, high resolution ADCs are sensitive to the quality of the clock input. The degradation in SNR at a given input frequency ( $f_A$ ) due only to aperture jitter ( $t_j$ ) can be calculated by

$$\text{SNR Degradation} = 20 \log_{10} \left( \frac{1}{2\pi \times f_A \times t_j} \right)$$

In this equation, the rms aperture jitter represents the root sum square of all jitter sources, including the clock input, analog input signal, and ADC aperture jitter specifications. Intermediate frequency (IF) under-sampling applications are particularly sensitive to jitter (see Figure 44).

Treat the clock input as an analog signal in cases where aperture jitter can affect the dynamic range of the CBM96AD56-125. Separate power supplies for clock drivers from the supplies for the ADC output driver to avoid modulating the clock signal with digital noise. Low jitter, crystal controlled oscillators make the best clock sources. If the clock is generated from another type of source (by gating, dividing, or other methods), retime it by the original clock at the last step.

Refer to the AN-501 Application Note and the AN-756 Application Note for more in depth information about jitter performance as it relates to ADCs.

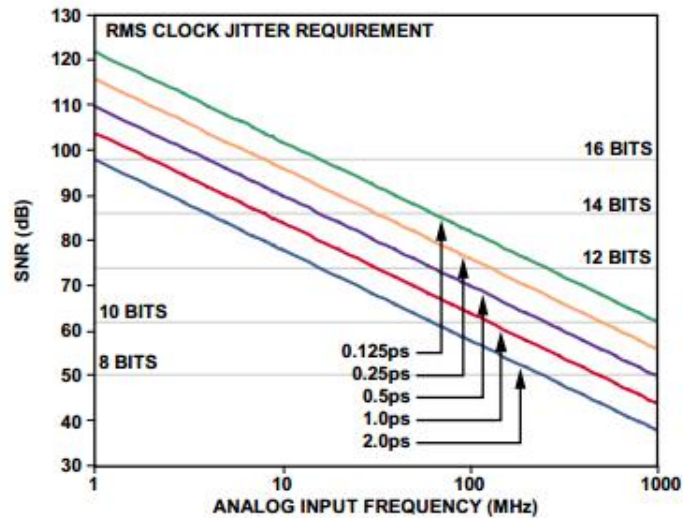

Figure 44. Ideal SNR vs. Analog Input Frequency and Jitter

### ● Power consumption and power saving mode

As shown in Figure 45 and Figure 46, the power dissipated by the CBM96AD56-125 is proportional to the sample rate.

The CBM96AD56-125 is placed in power-down mode either by the SPI port or by asserting the PDWN pin high. In power-down mode, the ADC typically dissipates 14 mW. During power-down, the output drivers are placed in a high impedance state. When the PDWN pin is asserted low, the CBM96AD56-125 returns to normal operating mode. Note that PDWN is referenced to SVDD and must not exceed that supply voltage.

Low power dissipation in power-down mode is achieved by shutting down the reference, reference buffer, biasing networks, and clock. Internal capacitors are discharged when entering power-down mode and must then be recharged when returning to normal operation. As a result, wake-up time is related to the time spent in power-down mode; shorter power-down cycles result in proportionally shorter wake-up times. When using the SPI port interface, the user can place the ADC in power-down mode or standby mode. Standby mode allows the user to keep the internal reference circuitry powered when faster wake-up times are required. See the Memory Map section for more information about using these features.



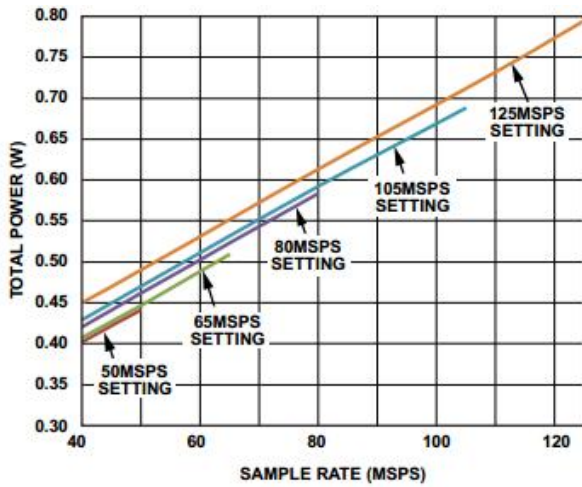

Figure 45. Total Power vs.  $f_{SAMPLE}$

( $f_{IN}=9.7\text{MHz}$ , 4 channels,  $V_{REF}=1.4\text{V}$ )

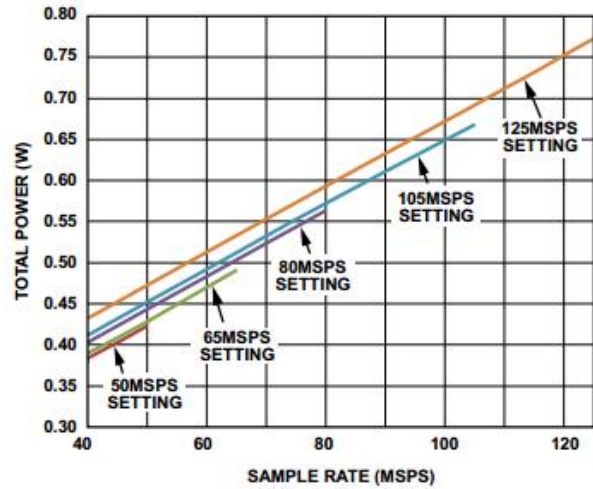

Figure 46. Total Power vs.  $f_{SAMPLE}$

( $f_{IN}=9.7\text{MHz}$ , 4channels,  $V_{REF}=1.0\text{V}$ )

## ● Digital output

### • JESD204B Transmit Top Level Description

The CBM96AD56-125 digital output uses the JEDEC Standard No. JESD204B, Serial Interface for Data Converters. JESD204B is a protocol to link the CBM96AD56-125 to a digital processing device over a serial interface with link speeds up to 8.0 Gbps. The benefits of the JESD204B interface include a reduction in the required board area for data interface routing and the enabling of smaller packages for converter and logic devices. The CBM96AD56-125 supports single, dual, and four lane interfaces.

### • JESD204B Overview

The JESD204B data transmit block, JTX, assembles the parallel data from the ADC into frames and uses 8b/10b encoding, as well as optional scrambling, to form serial output data. Lane synchronization is supported using special characters during the initial establishment of the link, and additional synchronization is embedded in the data stream thereafter. A matching external receiver is required to lock onto the serial data stream and recover the data and clock. For additional information about the JESD204B interface, refer to the JESD204B standard.

The CBM96AD56-125 JESD204B transmit block maps the output of the four ADCs over a link. A link can be configured to use either single, dual, or four serial differential outputs, which are called lanes. The JESD204B specification refers to a number of parameters to define the link, and these parameters must match between the JESD204B transmitter (CBM96AD56-125 output) and receiver.

**The JESD204B link is described according to the following parameters:**

- S = samples transmitted/single converter/frame cycle (CBM96AD56-125 value = 1)
- M = number of converters/converter device (CBM96AD56-125 value = 4)
- L = number of lanes/converter device (CBM96AD56-125 value = 1, 2, or 4)
- N = converter resolution (CBM96AD56-125 value = 16)
- N' = total number of bits per sample (CBM96AD56-125 value = 16)
- CF = number of control words/frame clock cycle/converter device (CBM96AD56-125 value = 0)
- CS = number of control bits/conversion sample (CBM96AD56-125 value = 0)
- K = number of frames per multiframe (configurable on the CBM96AD56-125)
- HD = high density mode (CBM96AD56-125 value = 0)
- F = octets/frame (CBM96AD56-125 value = 2, 4, or 8, dependent upon L = 4, 2, or 1)
- C = control bit (overrange, overflow, underflow; unavailable in the CBM96AD56-125 default mode)
- T = tail bit (unavailable in the CBM96AD56-125 default mode)
- SCR = scrambler enable/disable (configurable on the CBM96AD56-125)
- FCHK = checksum for the JESD204B parameters (automatically calculated and stored in the register map)

Figure 57 shows a simplified conceptual block diagram of the CBM96AD56-125 JESD204B link. By default, the CBM96AD56-125 is configured to use four converters and one lane. The CBM96AD56-125 allows for other configurations such as combining the outputs of two of the four converters onto a single lane resulting in the data from the four converters being output on two lanes. The mapping of the 0, 1, 2, and 3 digital output paths can be changed. These modes are set up through a quick configuration register in the SPI register map, along with additional customizable options.

By default in the CBM96AD56-125, the 16-bit word from each converter is divided into two octets (8 bits of data each). Bit 0 (MSB) through Bit 7 are in the first octet and Bit 8 through Bit 15 (LSB) are the second octet.

The two resulting octets can be scrambled. Scrambling is optional; however, it is available to avoid spectral peaks when transmitting similar digital data patterns. The scrambler uses a self synchronizing, polynomial-based algorithm defined by the equation  $1 + x^{14} + x^{15}$ . The descrambler in the receiver must be a self synchronizing version of the scrambler polynomial.

The two octets are then encoded with an 8b/10b encoder. The 8b/10b encoder works by taking eight bits of data (an octet) and encoding them into a 10-bit symbol. Figure 69 shows how the

16-bit data is output from the ADC, the two octets are scrambled, and how the octets are encoded into two 10-bit symbols. Figure 69 illustrates the default data format.

At the data link layer, in addition to the 8b/10b encoding, character replacement allows the receiver to monitor frame alignment. The character replacement process occurs on the frame and multiframe boundaries, and implementation depends on which boundary is occurring and if scrambling is enabled.

If scrambling is disabled, the following applies. If the last scrambled octet of the last frame of the multiframe equals the last octet of the previous frame, the transmitter replaces the last octet with the control character /A/ = /K28.3/. On other frames within the multiframe, if the last octet in the frame equals the last octet of the previous frame, the transmitter replaces the last octet with the control character /F/ = /K28.7/.

If scrambling is enabled, the following applies. If the last octet of the last frame of the multiframe equals 0x7C, the transmitter replaces the last octet with the control character /A/ = /K28.3/. On other frames within the multiframe, if the last octet equals 0xFC, the transmitter replaces the last octet with the control character /F/ = /K28.7/.

Refer to JEDEC Standard No. JESD204B (July 2011) for additional information about the JESD204B interface. Section 5.1 covers the transport layer and data format details, and Section 5.2 covers scrambling and descrambling.

- **JESD204B Synchronization Details**

The CBM96AD56-125 is a JESD204B Subclass 1 device and establishes synchronization of the link through two control signals (SYSREF and SYNCINB). At the system level, multiple converter devices are aligned using a common SYSREF signal and device clock (CLK).

The synchronization process is accomplished over three phases: code group synchronization (CGS), initial lane alignment sequence (ILAS), and data transmission. If scrambling is enabled, the bits are not scrambled until the data transmission phase. The CGS phase and ILAS phase do not use scrambling.

- **CGS Phase**

The assertion of the SYNCINB signal by the JESD204B Rx for more than 5 frames and 9 octets informs the JESD204B Tx to synchronize. To have the CBM96AD56-125 to respond by initiating the CGS phase, the SYNCINB signal must be asserted for at least 4 LMFC cycles if no SYSREF realignment is required. As illustrated in Figure 66, if SYSREF realignment is needed, the SYNCINB signal must be asserted for at least 6 LMFC cycles. In the CGS phase, the JESD204B transmit block transmits /K28.5/ characters. The receiver (external logic device) must find K28.5 characters in the input data stream using clock and data recovery (CDR) techniques.

When a certain number of consecutive K28.5 characters are detected on the link lanes, the receiver initiates a SYSREF edge so that the CBM96AD56-125 transmit data establishes a LMFC internally.

The SYSREF edge also resets any sampling edges within the ADC to align sampling instances to the LMFC. This is important to maintain synchronization across multiple devices.

The receiver or logic device deasserts the SYNCINB signal applied to the SYNCINB  $\pm$  pin according to the previously stated timing requirements.

#### • ILAS Phase

The ILAS phase begins on the second LMFC boundary after SYNCINB is deasserted; and the ILAS phase contents are as illustrated. The transmitter sends out the ILAS according to the JESD204B standard, and the receiver aligns all lanes of the link and verifies the parameters of the link.

The ILAS phase lasts for four multiframe and includes the following:

- ◆ Multiframe 1: Begins with an /R/ character [K28.0] and ends with an /A/ character [K28.3].
- ◆ Multiframe 2: Begins with an /R/ character followed by a /Q/ [K28.4] character, followed by link configuration parameters over 14 configuration octets (see Table 12), and ends with an /A/ character.
- ◆ Multiframe 3: same as Multiframe 1.
- ◆ Multiframe 4: same as Multiframe 1.

During the transmission of the ILAS, all data that is not a K28 control character or a configuration parameter is a repeating ramp pattern from 0 to 255. In the default state (M=4, L=1, K=32), there are 256 octets per multiframe, which allows the ramp to complete within Multiframe 1, 3, and 4. For configurations with less than 256 octets per multiframe, the ramp continues to rise into the next multiframe. Multiframe 2 has 14 configuration octets following a /Q/ character that is transmitted instead of ramp values. The ramp continues to advance internally while the 14 configuration octets are transmitted and ramp values appear again after the 14 configuration octets end.

Table 11. 14 Configuration Octets of the ILAS Phase

No.	Bit7(MSB)	Bit6	Bit5	Bit4	Bit3	Bit2	Bit1	Bit0(LSB)
0	DID[7:0]							
1					BID[3:0]			
2					LID[4:0]			
3	SCR				L[4:0]			
4	F[7:0]							
5					K[4:0]			

6	M[7:0]		
7	CS[1:0]		N[4:0]
8	SUBCLASS[2:0]		N' [4:0]
9	JESDV[2:0]		S[4:0]
10			CF[4:0]
11	Reserved, do not care(RES1)		
12	Reserved, do not care(RES2)		
13	FCHK[7:0]		

- **Data Transmission Phase**

In the data transmission phase, frame alignment is monitored with control characters. Character replacement is used at the end of frames. Character replacement in the transmitter occurs in the following instances:

- ◆ If scrambling is disabled and the last octet of the frame or multiframe equals the octet value of the previous frame.
- ◆ If scrambling is enabled and the last octet of the multiframe is equal to 0x7C, or the last octet of a frame is equal to 0xFC.

- **Link Setup Parameters**

The following demonstrates how to configure the CBM96AD56-125 JESD204B interface. The steps to configure the output include the following:

1. Disable the lanes before changing configuration.
2. Select one quick configuration option.
3. Configure the detailed options.
4. Check FCHK, checksum of JESD204B interface parameters.
5. Set additional digital output configuration options.
6. Reenable the lane(s).

- **Select Quick Configuration Option**

Write to Register 0x5E, the JESD204B quick configuration register to select the configuration options. See Table 12 for the configuration options and resulting JESD204B parameter values.

- ◆ 0x41 = four converters, one lane
- ◆ 0x42 = four converters, two lanes
- ◆ 0x44 = four converters, four lanes
- ◆ 0x21 = two converters, one lane
- ◆ 0x22 = two converters, two lanes
- ◆ 0x11 = one converter, one lane

Table 12. Quick Configuration

JESD204B Quick Configuration Setting, Register 0x5E	M (No. of Converters), Register 0x71, Bits[7:0]	L (No. of Lanes), Register 0x6E, Bits[4:0]	F (Octets/Frame), Register 0x6F, Bits[7:0], Read Only	S (Samples/ADC/Frame), Register 0x74, Bits[4:0], Read Only	HD (High Density Mode), Register 0x75, Bit[7], Read Only
0x41	4	1	8	1	0
0x42	4	2	4	1	0
0x44	4	4	2	1	0
0x22	2	2	2	1	0
0x21	2	1	4	1	0
0x11	1	1	2	1	0

### • Configure Detailed Options

Configure the tail bits and control bits.

- ◆ With  $N' = 16$  and  $N = 14$  (nondefault configuration), two bits are available per sample for transmitting additional information over the JESD204B link. The options are tail bits or control bits. By default, tail bits of 0b00 value are used.
- ◆ Tail bits are dummy bits sent over the link to complete the two octets and do not convey any information about the input signal. Tail bits can be fixed zeros (default) or pseudo-random numbers (Register 0x5F, Bit 6).
- ◆ One or two control bits can be selected to replace the tail bits using Register 0x72, Bits[7:6]. The meaning of the control bits can be set using Register 0x14, Bits[7:5].

Set lane identification values.

- ◆ JESD204B allows parameters to identify the device and lane. These parameters are transmitted during the ILAS phase, and they are accessible in the internal registers.
- ◆ The three identification values are device identification (DID), bank identification (BID), and lane identification (LID). DID and BID are device specific; therefore, they can be used for link identification.

Set the number of frames per multiframe, K.

- ◆ Per the JESD204B specification, a multiframe is defined as a group of K successive frames, where K is from 1 to 32, and requires that the number of octets be from 17 to 1024. The K value is set to 32 by default in Register 0x70, Bits[4:0]. Note that the K value is the register value plus 1.

- ◆ The K value can be changed; however, it must comply with a few conditions. The CBM96AD56-125 uses a fixed value for octets per frame (F) based on the JESD204B quick configuration setting. K must also be a multiple of 4 and conform to the following equation:  
 $32 \geq K \geq \text{Ceil}(17/F)$
- ◆ The JESD204B specification also specifies that the number of octets per multiframe ( $K \times F$ ) be from 17 to 1024. The F value is fixed through the quick configuration setting to ensure that this relationship is true.

Table 13. JESD204B Configurable Identification Values

DID Value	Register, Bits	Value Range
LID(Lane 0)	0x66, [4:0]	0...31
LID(Lane 1)	0x67, [4:0]	0...31
DID	0x64, [7:0]	0...255
BID	0x65, [3:0]	0...15

#### • Scramble, SCR

Scrambling can be enabled or disabled by setting Register 0x6E, Bit 7. By default, scrambling is enabled. Per the JESD204B protocol, scrambling is functional only after the lane synchronization has completed.

Select lane synchronization options.

Most of the synchronization features of the JESD204B interface are enabled by default for typical applications. In some cases, these features can be disabled or modified as follows:

- ◆ ILAS enabling is controlled in Register 0x5F, Bits[3:2] and is enabled by default. Optionally, to support some unique instances of the interfaces (such as NMCDASL), the JESD204B interface can be programmed to either disable the ILAS sequence or continually repeat the ILAS sequence.

The CBM96AD56-125 has fixed values for some JESD204B interface parameters, and they are as follows:

- ◆ [N'] = 16: number of bits per sample is 16, in Register 0x73, Bits[4:0]
- ◆ [CF] = 0: number of control words/frame clock cycle/converter is 0, in Register 0x75, Bits[4:0]

Verify read only values: lanes per link (L), octets per frame (F), number of converters (M), and samples per converter per frame (S). The CBM96AD56-125 calculates values for some JESD204B parameters based on other settings, particularly the quick configuration register selection. The following read only values are available in the register map for verification:

- ◆ [L] = lanes per link can be 1, 2 or 4; read the values from Register 0x6E, Bits [4:0]

- ◆ [F] = octets per frame can be 2, 4, or 8; read the value from Register 0x6F, Bits[7:0]
- ◆ [HD] = high density mode is 0; read the value from Register 0x75, Bit 7
- ◆ [M] = number of converters per link; default is 4, but can be 1, 2, or 4. Read the value from Register 0x71, Bits[7:0]
- ◆ [S] = samples per converter per frame is 1; read the value from Register 0x74, Bits[4:0]

• **Check FCHK, Checksum of JESD204B Interface Parameters**

The JESD204B parameters can be verified through the checksum value [FCHK] of the JESD204B interface parameters. Each lane has a FCHK value associated with it. The FCHK value is transmitted during the ILAS second multiframe and can be read from the internal registers.

The checksum value is the modulo 256 sum of the parameters listed in the No. column of Table 14. The checksum is calculated by adding the parameter fields before they are packed into the octets shown in Table 14.

The FCHK for the lane configuration for data exiting Lane 0 can be read from Register 0x78. Similarly, the FCHK for the lane configuration for data exiting Lane 1 can be read from Register 0x79, FCHK for Lane 2 can be read from Register 0x7A, and FCHK for Lane 3 can be read from Register 0x7B.

Table 14. JESD204B Configuration Table Used in ILAS and CHKSUM Calculation

No.	Bit 7(MSB)	Bit 6	Bit 5	Bit 4	Bit 3	Bit 2	Bit 1	Bit 0(LSB)
0	DID[7:0]							
1					BID[3:0]			
2				LID[4:0]				
3	SCR			L[4:0]				
4	F[7:0]							
5				K[4:0]				
6	M[7:0]							
7	CS[1:0]			N[4:0]				
8	SUBCLASS[2:0]			N' [4:0]				
9	JESDV[2:0]			S[4:0]				
10				CF[4:0]				

• **Set Additional Digital Output Configuration Options**

Other data format controls include the following:

- ◆ Invert polarity of serial output data: Register 0x60, Bit 1
- ◆ ADC data format (offset binary or twos complement): Register 0x14, Bits[1:0]



- ◆ Options for interpreting signals on the SYSREF ± and SYNCINB ± pins: Register 0x3A, Bits[4:3]
- ◆ Option to remap converter (logical lane) and SERDOUTx ± (physical lane) assignments: Register 0x82 and Register 0x83. See Figure 68 for a simplified conceptual block diagram.

• **Reenable Lanes After Configuration**

After modifying the JESD204B link parameters, enable the link so that the synchronization process can begin. This is accomplished by writing Logic 0 to Register 0x5F, Bit 0.

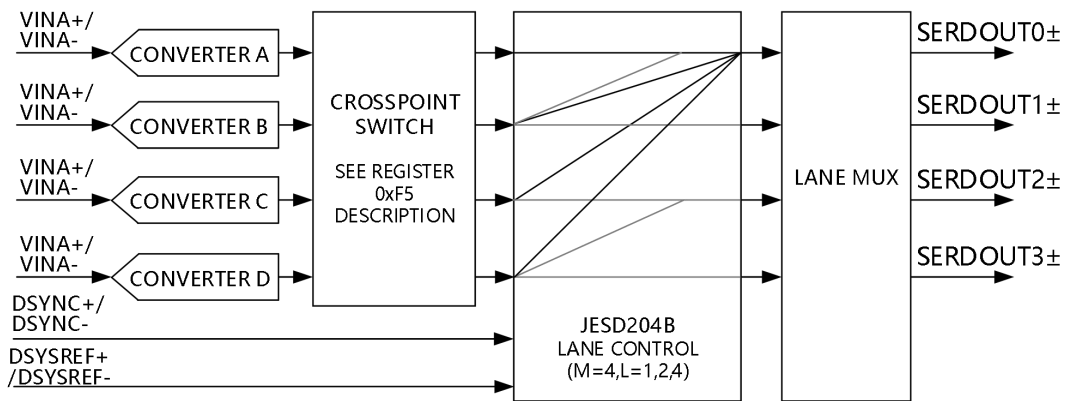

Figure 57. Transmit Link Simplified Conceptual Block Diagram

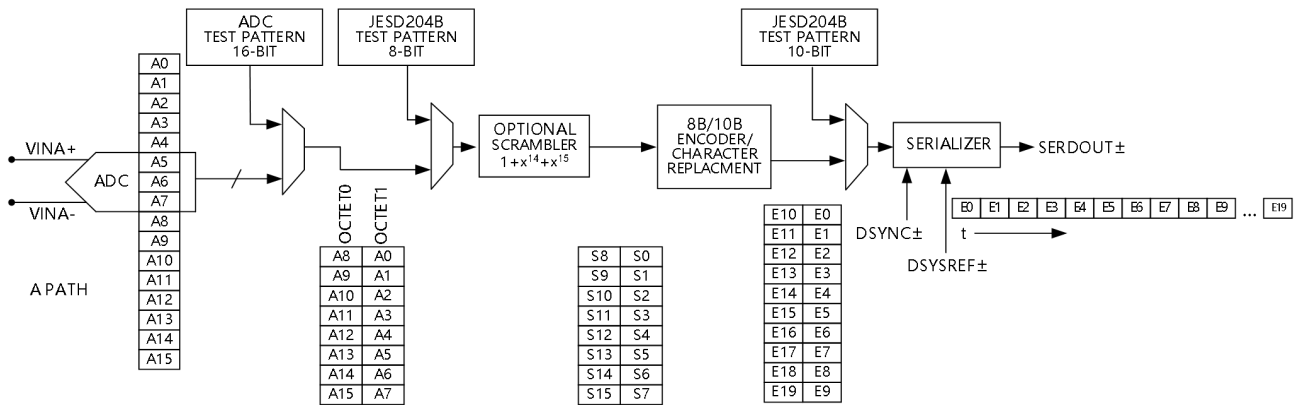

Figure 58. Digital Processing of JESD204B Lanes

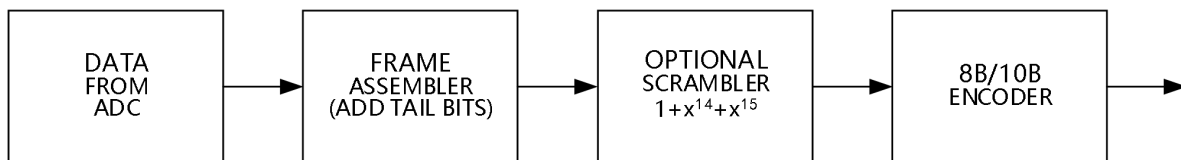

Figure 59. ADC Output Data Path

- **Frame and Lane Alignment Monitoring and Correction**

Frame alignment monitoring and correction is part of the JESD204B specification. The 16-bit word requires two octets to transmit all the data. The two octets (MSB and LSB), where  $F = 2$ , make up a frame. During normal operating conditions, frame alignment is monitored via alignment characters, which are inserted under certain conditions at the end of a frame. Table 16 summarizes the conditions for character insertion, along with the expected characters under the various operation modes. If lane synchronization is enabled, the replacement character value depends on whether the octet is at the end of a frame or at the end of a multiframe. Based on the operating mode, the receiver can ensure that it is still synchronized to the frame boundary by correctly receiving the replacement characters.

Scrambling	Lane Synchronization	Character to be Replaced	Last Octet in Multiframe	Replacement Character
Off	On	Last octet in frame repeated from previous frame	No	K28.7
Off	On	Last octet in frame repeated from previous frame	Yes	K28.3
Off	Off	Last octet in frame repeated from previous frame	Not applicable	K28.7
On	On	Last octet in frame equals D28.7	No	K28.7
On	On	Last octet in frame equals D28.3	Yes	K28.3
On	Off	Last octet in frame equals D28.7	Not applicable	K28.7

Table 15. JESD204B Frame Alignment Monitoring and Correction Replacement Characters

- **Digital Outputs and Timing**

The CBM96AD56-125 has differential digital outputs that power up by default. The driver current is derived on chip and sets the output current at each output equal to a nominal 3 mA. Each output presents a 100  $\Omega$  dynamic internal termination to reduce unwanted reflections.

The CBM96AD56-125 digital outputs can interface with custom ASICs and FPGA receivers, providing superior switching performance in noisy environments. Single point to point network topologies are recommended with a single differential 100  $\Omega$  termination resistor placed as close to the receiver logic as possible.

For receiver inputs that are self biased, or with input common mode requirements not within the bounds of the CBM96AD56-125 DRVDD supply, use an ac-coupled connection as shown in Figure 60. Place a 0.1  $\mu$ F series capacitor on each output pin and use a 100  $\Omega$  differential termination close to the receiver side. The 100  $\Omega$  differential termination results in a nominal 600 mV p-p differential swing at the receiver. In the case where the receiver inputs are not self biased, single-ended 50  $\Omega$  terminations can be used. When single-ended terminations are used, the termination voltage (VRXCM) must be chosen to match the input requirements of the receiver.

For receivers with input common mode voltage requirements matching the output common mode voltage (DRVDD/2) of the CBM96AD56-125, a dc-coupled connection can be used. The common mode of the digital output automatically biases itself to half of DRVDD (0.9 V for DRVDD = 1.8 V) (see Figure 61).

If there is no far-end receiver termination, or if there is poor differential trace routing, timing errors can result. To avoid such timing errors, it is recommended that the trace length be less than six inches and the differential output traces be close together and of equal lengths. Figure 62 shows an example of the digital output data eye and time interval error (TIE) jitter histogram and bathtub curve for an CBM96AD56-125 lane running at 6.4 Gbps. The maximum allowable data rate per lane is 8 Gbps. In some configurations, the CBM96AD56-125 maximum conversion rate is limited by the maximum allowable data rate. The output data rate per lane is calculated as

follows: 
$$\text{Data Rate} = (M \times N \times (10 / 8) \times \text{Sample Rate}) / L$$

where M (number of converters), N (resolution), and L (Number of lanes) are defined in the JESD204B Overview section. For example, with M = 4, N = 16, and L = 1; the sample rate is limited to 100 Msps.

Additional SPI options allow the user to further increase the output driver voltage swing of all four outputs to drive longer trace lengths (see Register 0x15 in Table 19). The power dissipation of the DRVDD supply increases when this option is used. See the Memory Map section for more information.

The format of the output data is twos complement by default. To change the output data format to offset binary, see the Memory Map section and Register 0x14 in Table 16.

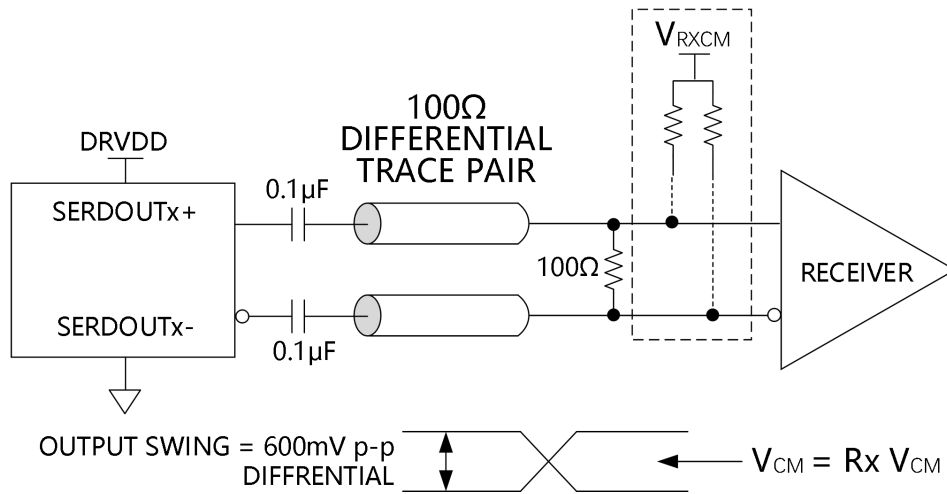

Figure 60. AC-Coupled Digital Output Termination Example

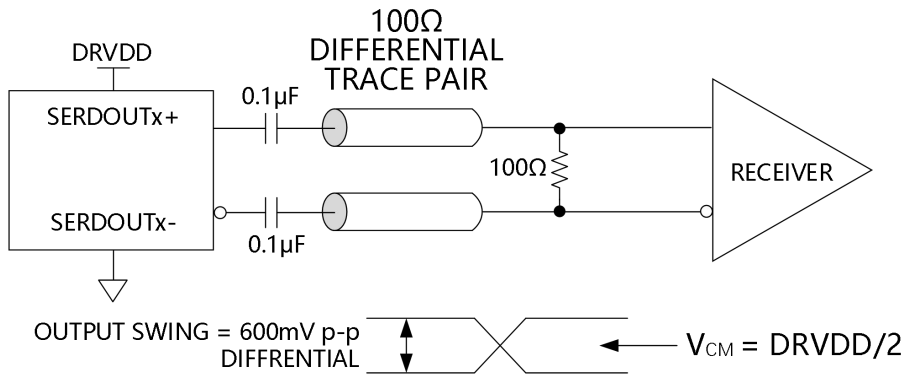

Figure 61. DC-Coupled Digital Output Termination Example

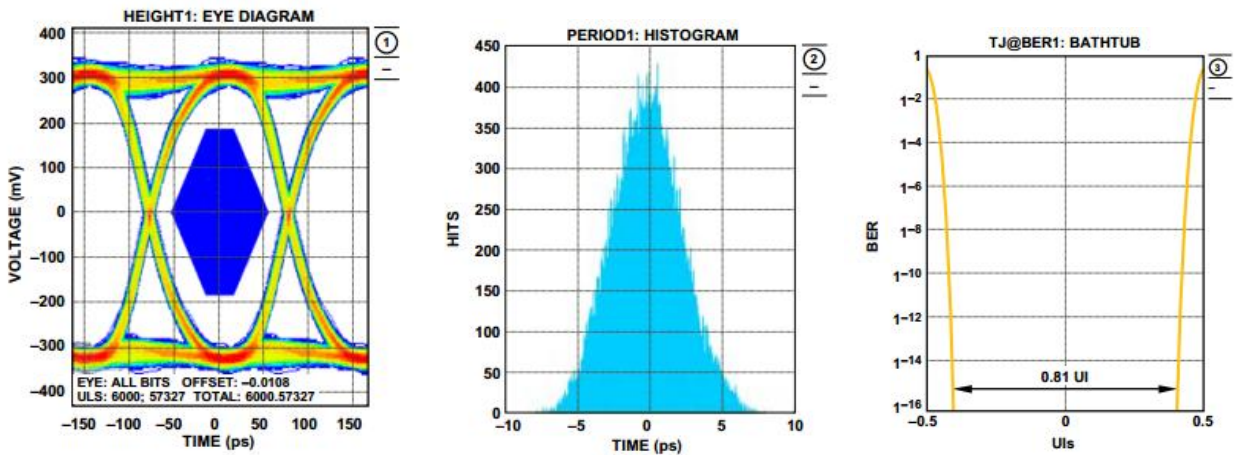

Figure 62. Digital Outputs Data Eye, Histogram, and Bathtub, External 100 Ω Terminations at 6.4 Gbps

- **Frame and Lane Alignment Monitoring and Correction**

Frame alignment monitoring and correction is part of the JESD204B specification. The 16-bit word requires two octets to transmit all the data. The two octets (MSB and LSB), where  $F = 2$ , make up a frame. During normal operating conditions, frame alignment is monitored via alignment characters, which are inserted under certain conditions at the end of a frame. Table 16 summarizes the conditions for character insertion, along with the expected characters under the various operation modes. If lane synchronization is enabled, the replacement character value depends on whether the octet is at the end of a frame or at the end of a multiframe. Based on the operating mode, the receiver can ensure that it is still synchronized to the frame boundary by correctly receiving the replacement characters.

- **Memory map**

- **READING THE MEMORY MAP REGISTER TABLE**

Each row in the memory map register table has eight bit locations. The memory map is roughly divided into three sections: the chip configuration registers (Address 0x00 to Address 0x02); the channel index and transfer registers (Address 0x05 and Address 0xFF); and the ADC functions registers, including setup, control, and test (Address 0x08 to Address 0x10A).

The memory map register table (see Table 16) documents the default hexadecimal value for each hexadecimal address shown. The column with the heading Bit 7 (MSB) is the start of the default hexadecimal value given. For example, Address 0x14, the output mode register, has a hexadecimal default value of 0x01. This means that Bit 0 = 1 and the remaining bits are 0s. This setting is the default output format value, which is twos complement. For general information on this function and others, see the AN-877 Application Note, Interfacing to High Speed ADCs via SPI. See Table 19 for SPI register information specific to the CBM96AD56-125.

- **Open and Reserved Locations**

All address and bit locations that are not included in Table 19 are not supported for this device. Write 0s to unused bits of a valid address location. Writing to these locations is required only when part of an address location is open (for example, Address 0x18). If the entire address location is open (for example, Address 0x13), do not write to this address location.

- **Default Values**

After the CBM96AD56-125 is reset, critical registers are loaded with default values. The default values for the registers are given in the memory map register table (see Table 16).

- **Logic Levels**

An explanation of logic level terminology follows:

- ◆ “Bit is set” is synonymous with “bit is set to Logic 1” or “writing Logic 1 for the bit.”

- ◆ “Clear a bit” is synonymous with “bit is set to Logic 0” or “writing Logic 0 for the bit.”

- **Channel Specific Registers**

Some channel setup functions can be programmed to a different value for each channel. In these cases, channel address locations are internally duplicated for each channel. These registers and bits are designated in Table 16 as local. These local registers and bits can be accessed by setting the appropriate Channel 0, Channel 1, Channel 2, or Channel 3 bit in Register 0x05. If four bits are set, the subsequent write affects the registers of all four channels. In a read cycle, set only one of the channels to read one of the four registers. If all bits are set during an SPI read cycle, the device returns the value for Channel 0. Registers and bits designated as global in Table 16 affect the entire device and the channel features for which independent settings are not allowed between channels. The settings in Register 0x05 do not affect the global registers and bits.

### • MEMORY MAP REGISTER TABLE

The CBM96AD56-125 uses a 3-wire interface and 16-bit addressing. Bit 0 and Bit 7 in Register 0x00 are set to 0, and Bit 3 and Bit 4 are set to 1. When Bit 5 in Register 0x00 is set high, the SPI enters a soft reset, where all of the user registers revert to each default value and Bit 2 is automatically cleared.

Table 16. Memory Map Registers (SPI Registers/Bits Not Labeled Local Are Global)

Addr( Hex)	Register Names	Bit 7 (MSB)	Bit 6	Bit 5	Bit 4	Bit 3	Bit 2	Bit 1	Bit 0 (LSB)	Default Value(Hex)	Notes/Comments
Chip Configuration Registers											
0x00	SPI port configuration	0	LSB first	Soft reset	1	1	Soft reset	LSB first	0	0x18	
0x01	Chip ID	8-bit chip ID[7:0]; CBM96AD56-125=0xC0(Quad、16位、125MSPS、JESD204B)								0xC0	Read Only
0x02	Device index	Open	Speed grade ID[6:4]; 110=125MSPS			Open	Open	Open	Open	0x60	Read Only
Channel Index and Transfer Registers											
0x05	Device index	Open	Open	Open	Open	Data Channel 3	Data Channel 2	Data Channel 1	Data Channel 0	0x0F	
0xFF	Transfer	Open	Open	Open	Open	Open	Open	Open	Initiate Register 0X100 override (self clearing)	0x00	
ADC Functions											
0x08	Power modes	Open	Open	PDW N pin function: 0=full power-down, 1=standby	JTX standby mode: 0=ignore standby, 1=do not ignore standby	Reserved			Power mode: 00=normal operation, 01=full power-down, 10=standby 11=digital reset	0x00	
0x09	Clock	Open	0	Open	Open	Open	Open	Open	Duty cycle stabilize	0x00	

										r: 0=off, 1=on		
0x0A	PLL_STATUS	PLL locked Status bit: 0=PLL is not locked, 1=PLL is locked	Open	Open	Open	Open	Open	Open	Open	JTX link status: 0=not ready, 1=ready		Read Only
0x0B	Clock divider	Open	Open	Open	Open	Open	Clock divider ratio[2:0]: 000=divide by 1, 001=divide by 2, 010=divide by 3, 011=divide by 4, 100=divide by 5, 101=divide by 6, 110=divide by 7, 111=divide by 8,			0x00		
0x0C	Enhancement control	Open	Open	Open	Open	Open	Chop mode: 0=off 1=on	Open	Open	0x00		
0x0D	Test mode(local except for pseudo-random number(PN)sequence resets)	User input test mode: 00=single 01=alternate 10=single once 11=alternate once, (affects user input test mode only,Bits[3:0]=1000)	Reset PN long generator	Reset PN short generator	Output test mode[3:0](local): 0000=off(default), 0001=midscale short, 0010=positive full scale(FS), 0011=negative FS, 0100=alternating checkerboard, 0101=PN23 sequence, 0110=PN9 sequence, 0111=one/zero word toggle, 1000=user input, 1001=1/0 bit toggle, 1010=1X sync 1011=one bit high 1100=mixed bit frequency			When set,the test data is placed on the output pins in place of normal data.				
0x10	Offset adjust(local)	8-bit device offset adjustment[7:0](local); offset adjusts in LSB from +127 to -128(twos complement format)								0x00	Device offset trim	
0x14	Output mode	JTX CS mode: 000={overrange  underrange,valid flag}	ADC output disable	Open	Open	Output format: 00=offset binary, 01=twos		0x01	Bits[7:5] are not applica			



		001={overrange  underrange}	:	complement		ble when using the default 16-bit resolution					
		010={overrange  underrange,blank}	0=enabled, 1=disabled(local)								
		011={blank.valid flag}									
		100={blank,blank}									
		Others={overrange  underrange,valid flag}									
0x15	Output adjust	Open	Open	Open	Open	Open	Typical CML differential output drive level: 000=473mVp-p, 001=524mVp-p, 010=574mVp-p, 011=621mVp-p(default), 100=667mVp-p, 101=716mVp-p, 110=763mVp-p, 111=811mVp-p	0x03			
0x16	Clock phase control	Open	Input clock phase adjust[2:0] (value is number of input clock cycles of phase delay)		Open	Open	Open	Open	0x00		
0x18	Input span select	Internal VREF adjustment[1:0]: 00=1.0V, 01=1.2V, 10=1.3V, 11=1.4V		Open	Open	Open	Differential span adjustment: 000=50% of normal, 001=57% of normal, 010=67% of normal, 011=80% of normal, 100=normal		0x04		
0x19	User Test Pattern 1 LSB	User Test Pattern 1[7:0]							0x00		
0x1A	User Test Pattern 1 MSB	User Test Pattern 1[15:8]							0x00		
0x1B	User Test Pattern 2 LSB	User Test Pattern 2[7:0]							0x00		
0x1C	User Test Pattern 2 MSB	User Test Pattern 2[15:8]							0x00		
0x21	FLEX_SERIAL_CONTROL	Open	Open	Open	Open	PLL low rate mode: 0=lane rate≥2	Open	Open	Open	0x00	

						Gbps 1=lane rate<2 Gbps					
0x22	FLEX_SERIAL_ CH_STAT	Open	Open	Open	Open	Open	Open	Open	Channel power-down (local)	0x00	
0x3A	SYSREF_CTRL	Open	Open	Open	0=normal mode, 1=realignment every DSYSREF±	0=realign the lanes only when DSYSREF± causes a resync of the counters, 1=realign the lanes on every DSYSREF±	Open	Open	Open	0x00	
0x3B	REALIGN_PATTERN_CTRL	This pattern is written into the FIFO when a lane is being aligned: 00 = lane outputs constant zero, 55 = lane outputs toggling pattern								0x55	
0x5E	JESD204B Quick configuration	0x41 = four converters, one lane; 0x42 = four converters, two lanes; 0x44 = two converters, two lanes; 0x21 = two converters, one lane; 0x11 =								0x00	Self clearing always reads 0x00.
0x5F	JESD204B Link CTRL 1	Open	Tail bits mode: 0 = fill with 0s, 1 = fill with 9-bit PN sequence	JTX transport layer test: 0 = not enabled, 1 = long transport	Multiframe alignment character insertion: 0 = disabled, 1 = enabled	ILAS mode: 00 = ILAS disabled, 01 = ILAS enabled (normal mode), 11 = ILAS always on (test mode)	Frame alignment character insertion: 0 = enabled, 1 = disabled	0 = JTX link enabled, 1 = JTX link disabled	0x14		

				layer test enabled							
0x60	JESD204B Link CTRL 2	Reserved		SYNClNB± pin invert: 0 = not inverted, 1 = inverted	SYNClNB± pin input bias: 0 = disabled, 1 = enabled	Open	Open	JTX output invert: 0 = normal, 1 = inverted	Reserved	0x10	
0x61	JESD204B Link CTRL 3	Reserved	Reserved	Test data injection point: 01 = 10-bit data injected at 8b/10b encoder output, 10 = 8-bit data at scrambler input	JTX test mode patterns: 0000 = normal operation (test mode disabled), 0001 = alternating checkerboard, 0010 = 1/0 word toggle, 0011 = PN sequence PN23, 0100 = PN sequence PN9, 0101 = continuous/repeat user test mode, 0110 = single user test mode, 0111 = reserved, 1000 = modified RPAT test sequence (8-bit data only), 1100 = PN sequence PN7, 1101 = PN sequence PN15, other setting are unused					0x00	
0x62	JESD204B Link CTRL 4	Reserved								0x00	
0x64	JESD204B DID Configuration	Device identification (DID) = C0								0xC0	Read Only
0x65	JESD204BBID Configuration	Open	Open	Open	Open	JTX bank identification (BID) number			0x00		
0x66	JESD204B LID Configuration 0	Open	Open	Open	JTX lane identification (LID) number for Lane 0			0x00			
0x67	JESD204B LID Configuration 1	Open	Open	Open	JTX lane identification (LID) number for Lane 1			0x01			
0x68	JESD204B LID Configuration 2	Open	Open	Open	JTX lane identification (LID) number for Lane 2			0x02			
0x69	JESD204B LID Configuration	Open	Open	Open	JTX lane identification (LID) number for Lane 3			0x03			

	3										
0x6E	JESD204B parameters, SCR/L	JESD204B scrambling (SCR): 0 = disabled, 1 = enabled	Open	Open		JESD204B serial lane control: 0 = one lane per link (L = 1), 1 = two lanes per link (L = 2), 2 = unused, 3 = four lanes per link (L = 4), 4 to 31 = unused				0x80	
0x6F	JESD204B parameters, F	JESD204B number of octets per frame (F); calculated value, $F = (2 \times M)/L$								0x00	Read Only
0x70	JESD204B parameters, K	Open	Open	Open		JESD204B number of frames per multiframe (K); K = register contents + 1, but also must be a multiple of four octets				0x1F	
0x71	JESD204B parameters, M	JESD204B number of converters (M): 0 = one converter (M = 1), 1 = two converters (M = 2), 3 = four converters (M = 4, default)								0x03	
0x72	JESD204B parameters, CS/N	00 = number of control bits sent per sample (CS = 0)	Open			JTX converter resolution (N): 0x0F = 16-bit, 0x0D = 14-bit, 0x0B = 12-bit, 0x09 = 10-bit				0x0F	
0x73	JESD204B parameters, subclass/Np	JESD204B subclass; 0x0 = Subclass 0; 0x1 = Subclass 1 (default)				JESD204B number of bits per sample (N'); N' = register contents + 1				0x2F	
0x74	JESD204B parameters, S	Reserved				JESD204B converter samples per frame (S); S = register contents + 1				0x20	Read Only
0x75	JESD204B parameters, HD and CF	JESD204B HD value = 0	Open	Open		JESD204B control words per frame clock cycle per link (CF = 0, fixed)				0x00	Read Only
0x76	JESD204BRESV1	JESD204B Serial Reserved Field No. 1 in link configuration, see Table 12 (RES1)								0x00	
0x77	JESD204BRESV2	JESD204B Serial Reserved Field No. 2 in link configuration, see Table 12 (RES2)								0x00	
0x78	JESD204BCHKSUM0	JESD204B serial checksum value in link configuration, see Table 12 for Lane 0 (FCHK)									Read Only
0x79	JESD204BCHKSUM1	JESD204B serial checksum value in link configuration, see Table 12 for Lane 1 (FCHK)									Read Only
0x7A	JESD204BCHKSUM2	JESD204B serial checksum value in link configuration, see Table 12 for Lane 2 (FCHK)									Read Only
0x7B	JESD204BCHKSUM3	JESD204B serial checksum value in link configuration, see Table 12 for Lane 3 (FCHK)									Read Only
0x80	JTX physical lane disable	Open	Open	Open	Open	Lane 3: 0 =	Lane 2: 0 =	Lane 1: 0 =	Lane 0: 0 =	0x00	Lane serialize

						enable d, 1 = disable d	enable d, 1 = disable d	enable d, 1 = disable d	enabled, 1 = disabled		and output driver powered down.	
0x82	JESD204B Lane Assign 1	Open	Physical Lane 1 assignment: 000 = Logical Lane 0, 001 = Logical Lane 1, 010 = Logical Lane 2, 011 = Logical Lane 3			Open	Physical Lane 0 assignment: 000 = Logical Lane 0, 001 = Logical Lane 1, 010 = Logical Lane 2, 011 = Logical Lane 3				0x10	
0x83	JESD204B Lane Assign 2	Open	Physical Lane 3 assignment: 000 = Logical Lane 0, 001 = Logical Lane 1, 010 = Logical Lane 2, 011 = Logical Lane 3			Open	Physical Lane 2 assignment: 000 = Logical Lane 0, 001 = Logical Lane 1, 010 = Logical Lane 2, 011 = Logical Lane 3				0x32	
0x86	JESD204B Lane inversion	Open	Open	Open	Open	Lane 3: 0 = no invert, 1 = invert	Lane 2: 0 = no invert, 1 = invert	Lane 1: 0 = no invert, 1 = invert	Lane 0: 0 = no invert, 1 = invert	x00		
0x8B	JESD204BLM FC offset	Open	Open	Open	Local multiframe clock (LMFC) phase offset value; reset value for LMFC phase Local multiframe clock (LMFC) phase offset value; reset value for LMFC phase counter when SYSREF± is asserted; used for deterministic delay applications				0x00			
0xA0	JTX User Pattern Octet 0,LSB	User test pattern most significant byte,Octet 0								0x00		
0xA1	JTX User Pattern Octet 0,MSB	User test pattern most significant byte,Octet 0								0x00		
0xA2	JTX User Pattern Octet 1,LSB	User test pattern most significant byte,Octet 1								0x00		
0xA3	JTX User Pattern Octet 1,MSB	User test pattern most significant byte,Octet 1								0x00		
0xA4	JTX User Pattern Octet 2,LSB	User test pattern most significant byte,Octet 2								0x00		
0xA5	JTX User Pattern Octet 2,MSB	User test pattern most significant byte,Octet 2								0x00		

0xA6	JTX User Pattern Octet 3,LSB	User test pattern most significant byte,Octet 3								0x00		
0xA7	JTX User Pattern Octet 3,MSB	User test pattern most significant byte,Octet 3								0x00		
0xF5	JTX converter mapping	JTX Converter3: 0=ADCA, 1=ADCB, 2=ADCC, 3=ADCD	JTX Converter2: 0=ADCA, 1=ADCB, 2=ADCC, 3=ADCD	JTX Converter1: 0=ADCA, 1=ADCB, 2=ADCC, 3=ADCD	JTX Converter0: 0=ADCA, 1=ADCB, 2=ADCC, 3=ADCD					0xE4		
0x100	Resolution/sample rate override	Open	Override enable	Resolution: 0=16bits, 1=14bits, 2=12bits, 3=10bits	Open	Sample rate: 001=40MSPS, 010=50MSPS, 011=65MSPS, 100=80MSPS, 101=105MSPS, 110=125MSPS				0x00	Sample rate override(requires transfer register, 0xFF).	
0x101	User I/O Control 2	Open	Open	Open	Open	Open	Open	Open	SDIO pull-down	0x00	Disable SDIO pull-down	
0x102	User I/O Control 3	Open	Open	Open	Open	VCM power-down	Open	Open	Open	0x00	VCM control	
0x109	Clock divider sync control	Clock divider sync mode:0 =use SYNC pin,1=use SYSREF ±pins	Reserved						Reset clock divider sync received	Sync clock divider enable:0 =disabled,1=enabled	0x00	
0x10A	Clock divider sync received	Open	Open	Open	Open	Open	Open	Open	Clock divider sync received	0x00	Read Only	

## MEMORY MAP REGISTER DESCRIPTIONS

For additional general information about functions controlled in Register 0x00 to Register 0xFF, see the AN-877 Application Note, Interfacing to High Speed ADCs via SPI.

- **Device Index (Register 0x05)**

Certain features in the map that are designated as local can be set independently for each channel, whereas other features apply globally to all channels (depending on context), regardless of the channel is selected. Bits[3:0] of Register 0x05 can select which data channels are affected.

- **(Register 0xFF)**

All registers except Register 0x100 are updated the moment they are written. Setting Bit 0 of the transfer register high invokes the settings in the resolution/sample rate override register (Address 0x100).

- **Power Modes (Register 0x08)**

- ◆ Bit 5—PDWN Pin Function

If set to 1, the PDWN pin initiates standby mode. If set to 0 (cleared), the PDWN pin initiates full power-down mode.

- ◆ Bit 4—JTX Standby Mode

If set, the JTX block enters standby mode when chip standby is activated. Only the PLL is left running in standby mode. If cleared, the JTX block remains running when chip standby is activated.

- ◆ Bits[1:0]—Power Mode

In normal operation (Bits[1:0] = 00), all ADC channels and the JTX block are active.

In full power-down mode (Bits[1:0] = 01), all ADC channels and the JTX block are powered down, and the digital datapath clocks are disabled, while the digital datapath is reset. The outputs are disabled.

In standby mode (Bits[1:0] = 10), all ADC channels are partially powered down, and the digital datapath clocks are disabled. If JTX standby mode is set, the outputs are also disabled.

During a digital reset (Bits[1:0] = 11), all the digital datapath clocks and the outputs (where applicable) on the chip are reset, except for the SPI port.

Note that the SPI is always left under control of the user; that is, it is never automatically disabled or in reset (except by power-on reset). When the digital reset is deactivated, a foreground calibration sequence is initiated.

- **Enhancement Control (Register 0x0C)**

- ◆ Bit 2—Chop Mode

For applications that are sensitive to offset voltages and other low frequency noise, such as homodyne or direct conversion receivers, chopping in the first stage of the CBM96AD56-125 is a feature that can be enabled by setting Bit 2. In the frequency domain, chopping translates offsets and other low frequency noise to  $f_{CLK}/2$  where it can be filtered.

- **Output Mode (Register 0x14)**

- ◆ Bits[7:5]—JTX CS Mode

Defines the meaning of the JTX control bits.

- ◆ Bits[1:0]—Output Format

By default, this field is set to 1 for data output in twos complement format. Setting this field to 0 changes the output mode to offset binary.

- **Clock Phase Control (Register 0x16)**

- ◆ Bits[6:4]—Input Clock Phase Adjust

When the clock divider (Register 0x0B) is used, the applied clock is at a higher frequency than the internal sampling clock. Bits[6:4] determine at which phase the external clock sampling occurs. This is only applicable when the clock divider is used. Setting Bits[6:4] greater than Register 0x0B, Bits[2:0] is prohibited.

- **JTX User Pattern (Register 0xA0 to Register 0xA7)**

The pattern in these registers is output on all active lanes when Register 0x61, Bits[3:0] are set to 5 or 6. A 32-bit pattern, the concatenation of Register 0xA0, Register 0xA2, Register 0xA4, and Register 0xA6 is inserted before the scrambler if Register 0x61, Bits[5:4] are set to 2. If Register 0x61, Bits[5:4] are set to 1 (a 40-bit pattern), the concatenation of Register 0xA1, Bits[1:0] and Register 0xA0, Bits[7:0]; Register 0xA3, Bits[1:0] and Register 0xA2, Bits[7:0]; Register 0xA5, Bits[1:0] and Register 0xA4, Bits[7:0]; Register 0xA7, Bits[1:0] and Register 0xA6, Bits[7:0] is inserted after the 8b/10b encoder.

- **Resolution/Sample Rate Override (Register 0x100)**

This register allows the user to downgrade the resolution and/or the maximum sample rate (for lower power) in applications that do not require full resolution and/or sample rate. Settings in this register are not initialized until Bit 0 of the transfer register (Register 0xFF) is written high. Bits[2:0] do not affect the sample rate; they affect the maximum sample rate capability of the ADC.

Writing to Register 0x100 reverts other registers to defaults. If nondefault configurations are desired, write to Register 0x100 first, and then perform other desired SPI operations to preserve the desired configuration.



- **User I/O Control 2 (Register 0x101)**

**Bit 0—SDIO Pull-Down**

Bit 0 can be set to disable the internal 30 k $\Omega$  pull-down resistor on the SDIO pin. This setting can limit the loading when many devices are connected to the SPI bus.

- **User I/O Control 3 (Register 0x102)**

**Bit 3—VCM Power-Down**

Bit 3 can be set high to power down the internal VCM generator. This feature is used when applying an external reference.

## Applications Information

### ● DESIGN GUIDELINES

Before starting system level design and layout of the CBM96AD56-125, it is recommended that the designer become familiar with these guidelines, which discuss the special circuit connections and layout requirements needed for certain pins.

### ● CLOCK STABILITY CONSIDERATIONS

When powered on, the CBM96AD56-125 enters an initialization phase during which an internal state machine sets up the biases and the registers for proper operation. During the initialization process, the CBM96AD56-125 requires a stable clock. If the ADC clock source is not present or not stable during ADC power-up, it disrupts the state machine and causes the ADC to start up in an unknown state. To correct this, an initialization sequence must be reinvoked after the ADC clock is stable by issuing a digital reset via Register 0x08. In the default configuration (internal  $V_{REF}$ , ac-coupled input) where  $V_{REF}$  and  $V_{CM}$  are supplied by the ADC itself, a stable clock during power-up is sufficient. In the case where  $V_{REF}$  and/or  $V_{CM}$  are supplied by an external source, these, too, must be stable at power-up; otherwise, a subsequent digital reset via Register 0x08 is needed. Interruption of the sample clock during operation and changes in sample rate also necessitate a digital reset. The pseudo code sequence for a digital reset is as follows:

```
SPI_Write (0x08, 0x03); # Digital Reset  
SPI_Write (0x08, 0x00); # Normal Operation
```

### ● EXPOSED PAD THERMAL HEAT SLUG RECOMMENDATIONS

It is mandatory that the exposed pad on the underside of the ADC connect to analog ground (AGND) to achieve the best electrical and thermal performance. A continuous, exposed (no solder mask) copper plane on the PCB must mate to the CBM96AD56-125 exposed pad, Pin 0. The copper plane must have several vias to achieve the lowest possible resistive thermal path for heat dissipation to flow through the bottom of the PCB. Fill or plug these vias with nonconductive epoxy.

To maximize the coverage and adhesion between the ADC and the PCB, overlay a silkscreen to partition the continuous plane on the PCB into several uniform sections. This partitioning prevents the solder from pooling and provides several tie points between the ADC and the PCB during the reflow process. Using one continuous plane with no partitions guarantees only one tie point between the ADC and the PCB. See the evaluation board for a PCB layout example. For detailed information about the packaging and PCB layout of chip scale packages, refer to the AN-772 Application Note, A Design and Manufacturing Guide for the Lead Frame Chip Scale Package (LFCSP).

- **VCM**

Decouple the VCM pin to ground with a 0.1 $\mu$ F capacitor.

- **REFERENCE DECOUPLING**

Externally bypass the VREF pin to ground with a low ESR, 1.0  $\mu$ F capacitor in parallel with a low ESR, 0.1  $\mu$ F ceramic capacitor.

- **SPI PORT**

When the full dynamic performance of the converter is required, do not activate the SPI port. Because the SCLK, CSB, and SDIO signals are typically asynchronous to the ADC clock, noise from these signals can degrade converter performance. If the on-board SPI bus is used for other devices, it may be necessary to provide buffers between this bus and the CBM96AD56-125 to keep these signals from transitioning at the converter input pins during critical sampling periods.

- **POWER AND GROUND RECOMMENDATIONS**

When connecting power to the CBM96AD56-125, it is recommended to use separate 1.8 V supplies: one supply for analog (AVDD), a separate shared supply for the digital outputs (DRVDD), and the digital (DVDD). DRVDD must be kept at the same voltage as DVDD. SVDD can be shared with any of the other supplies if 1.8 V SPI operation is desired. The designer can use several different decoupling capacitors to cover both high and low frequencies. Locate these capacitors close to the point of entry at the PCB level and close to the pins of the device with minimal trace length.

When using the CBM96AD56-125, a single PCB ground plane is sufficient. With proper decoupling and smart partitioning of the PCB analog, digital, and clock sections, optimum performance is easily achieved.

## Package Outline Dimensions

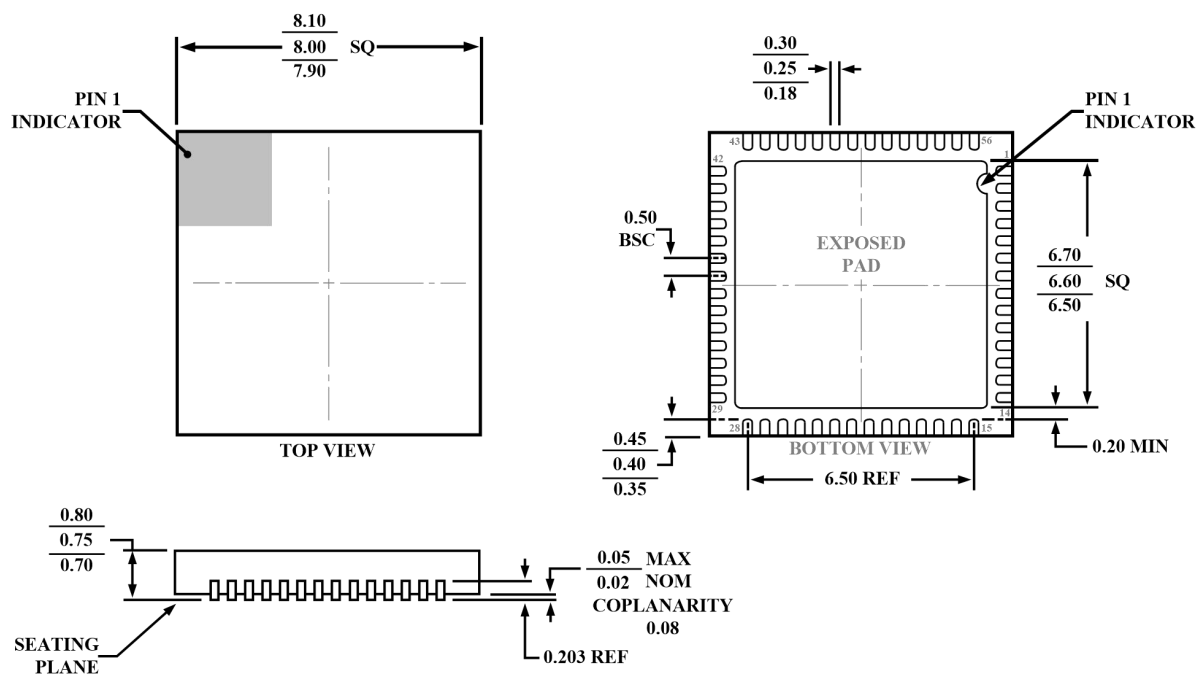

Figure 63.56 Pin lead packaging (plastic packaging)

8mm×8mm, Dimensions shown in millimeters

## Package/Ordering Information

MODEL	ORDER NUMBER	TEMPERATURE	PACKAGE DESCRIPTION	PACKAGE OPTION	MARKING INFORMATION
CBM96AD56-125		-40°C-85°C	QFN-56	Tray, 260	