

Features And Application

- Single or Split Supply Operation
- Low Input Bias Current
- Low Input Offset Current
- Input Common Mode Voltage Range to GND
- Low Output Saturation Voltage
- TTL and CMOS Compatible

Description

The CBM2901 consists of four independent precision voltage comparators with an offset voltage specification as low as 5.0 mV max for four comparators which were designed specifically to operate from a single power supply over a wide range of voltages.

Application areas include limit comparators, simple analog to digital converters, pulse, square wave, Zero crossing detector (single power supply) and time delay generators.

Logic Diagram

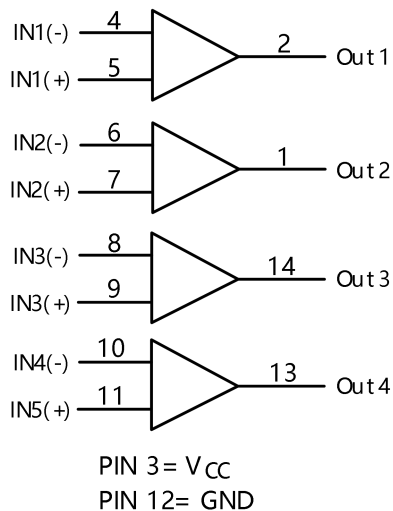

Pin Assignment

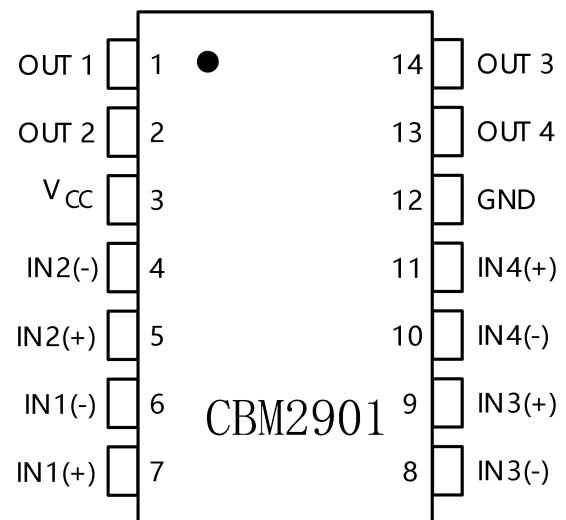

Catalog

Features And Application.....	1
Description.....	1
Logic Diagram.....	1
Pin Assignment.....	1
Catalog.....	2
Absolute Maximum Ratings.....	3
Recommended Operating Conditions.....	4
Electrical Characteristics	5
Typical Performance Characteristics.....	6
Outline Dimensions.....	7
SOP-14.....	7
Package/Ordering Information.....	8

Absolute Maximum Ratings

($T_A = +25^\circ\text{C}$, unless otherwise specified.)

Symbol	Parameter	Value	Unit
V_{CC}	Power Supply Voltages		
	Single Supply	36	V
	Split Supplies	± 18	
V_{IDR}	Input Differential Voltage Range	36	V
V_{ICR}	Input Common Mode Voltage Range (1)	-0.3 to V_{CC}	V
--	Output Short Circuit to Ground(2)	Unlimited	--
I_{IN}	Input Current, per pin (3)	50	mA
I_o	Output Current	20	mA
T_J	Junction Temperature		
	Plastic Packages	150	$^\circ\text{C}$
T_A	Operating Ambient Temperature	-40 to +125	$^\circ\text{C}$
T_{STG}	Storage Temperature Range	-65 to +150	$^\circ\text{C}$
T_L	Lead Temperature, 1mm from Case for 10 Seconds	260	$^\circ\text{C}$
P_D	Power Dissipation @$T_A=25^\circ\text{C}$		
	Plastic Package	1.0	W
	Derate above 25°C	8.0	mW/ $^\circ\text{C}$

* Stresses beyond those listed under “absolute maximum ratings” may cause permanent damage to the device. These are stress ratings only and functional operation of the device at these or any other conditions beyond those indicated under “recommended operating conditions” is not implied.

Exposure to absolute-maximum-rated conditions for extended periods may affect device reliability.

Functional operation should be restricted to the Recommended Operating Conditions. Notes:

1. Split Power Supplies.

- The maximum output current may be as high as 20 mA, independent of the magnitude of VCC.
- $V_{IN} < -0.3V$. This input current will only exist when voltage at any of the input leads is driven negative.

Recommended Operating Conditions

Symbol	Parameter	Min	Max	Unit
V _{CC}	DC Supply Voltage	±2.5 or 5.0	±15 or 30	V
T _A	Operating Temperature, All Package Types	-40	+125	°C

This device contains protection circuitry to guard against damage due to high static voltages or electric fields. However, precautions must be taken to avoid applications of any voltage higher than maximum rated voltages to this high-impedance circuit. For proper operation, V_{IN} and V_{OUT} should be constrained to the range $GND \leq (V_{IN} \text{ or } V_{OUT}) \leq V_{CC}$.

Unused inputs must always be tied to an appropriate logic voltage level (e.g., either GND or V_{CC}). Unused outputs must be left open.

Electrical Characteristics

($V_{CC} = 5.0V$, $GND = 0V$, $T_A = -40 \sim +125^{\circ}C$, unless otherwise specified)

Symbol	Parameter	Test Conditions	Guaranteed Limit			Unit
			Min	Typ	Max	
V_{IO}	Input Offset Voltage	$V_O=1.4V$ $V_{CC}=5.0V$ to $30V, R_S \leq 100\Omega$ $V_{ICR}=0V - (V_{CC}-1.5)V$	-		7.0*	mV
I_{IB}	Input Bias Current	$V_O=1.4V, V_{CC}=5.0-30V$ $V_{ICR}=0V$ to $(V_{CC}-1.5)V$	-		250	nA
I_{IO}	Input Offset Current	$V_O=1.4V, V_{CC}=5.0-30V$	-	5*	200*	nA
		$V_{ICR}=0V$ to $(V_{CC}-1.5)V$				
V_{ICR}	Input Common Mode Voltage Range	$V_{CC}=5.0V$ to $30V$	0		$V_{CC}-2.0V$	V
I_{CC}	Supply Current	$R_L=\infty, V_{CC}=5.0$ $R_L=\infty, V_{CC}=30V$	-	1.0*	2.5*	mA
A_{VOL}	Voltage Gain	$V_{CC}=15V, R_L=15K\Omega$	50	100*	-	V/mV
t_1	Large Signal Response Time	$V_{IN}=\text{TTL Logic Swing}, V_{ref}=1.4V,$ $V_{CC}=5.0V, R_L=5.1\Omega, V_{RL}=5.0V$	-	300*	-	ns
t_2	Response Time (Note 6)	$V_{CC}=5.0V, R_L=5.1K\Omega, V_{RL}=5.0V$	-	1.3*	-	μs
I_{SINK}	Output Sink Current	$V_i(-)=1.0V, V_i(+)=0V,$ $V_O \leq 1.5V, V_{CC}=5.0V$	6.0*	16	-	mA
V_{SAT}	Saturation Voltage	$V_i(-)=1.0V, V_i(+)=0V,$ $I_{sink} \leq 4.0mA, V_{CC}=5.0V$	-	-	700	mV
I_{OL}	Output Leakage Current	$V_i(+)=1.0V, V_i(-)=0V$	$V_O=5.0V$	0.1*		nA
			$V_O=30V$		1000	
V_{IDR}	Differential Input Voltage Range	All $V_{IN} \geq GND$ or V -Supply (if used)			V_{CC}^*	V

*=@25°C

Typical Performance Characteristics

($V_{CC}=1.5V$, $T_A=+25^{\circ}C$, (each comporator))

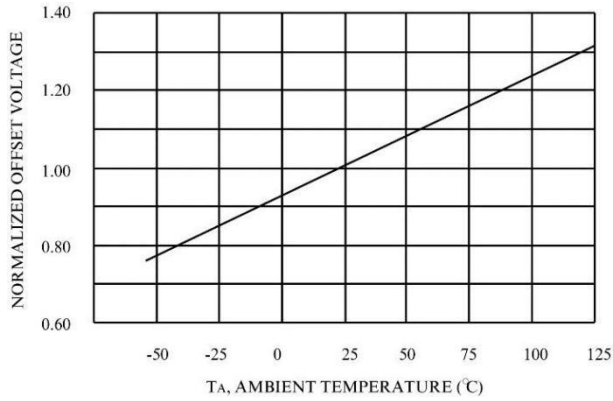

Figure 1. Normalized Input Offset Voltage

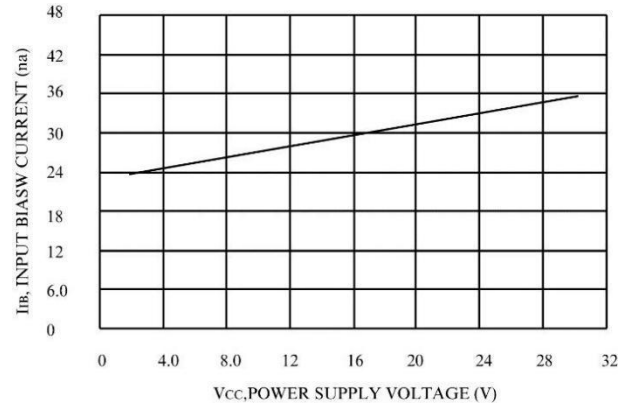

Figure 2. Input Bias Current

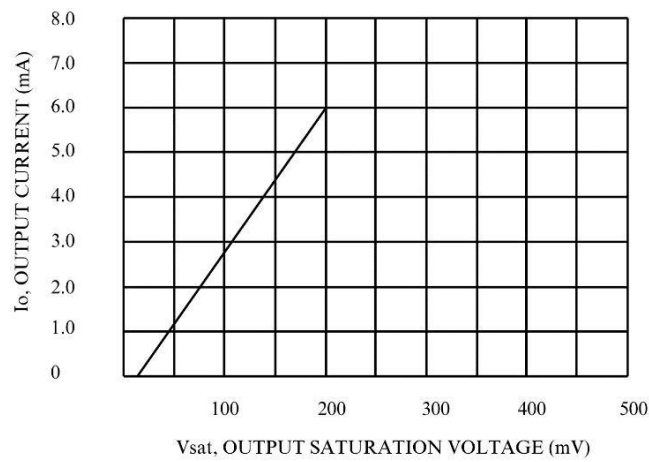
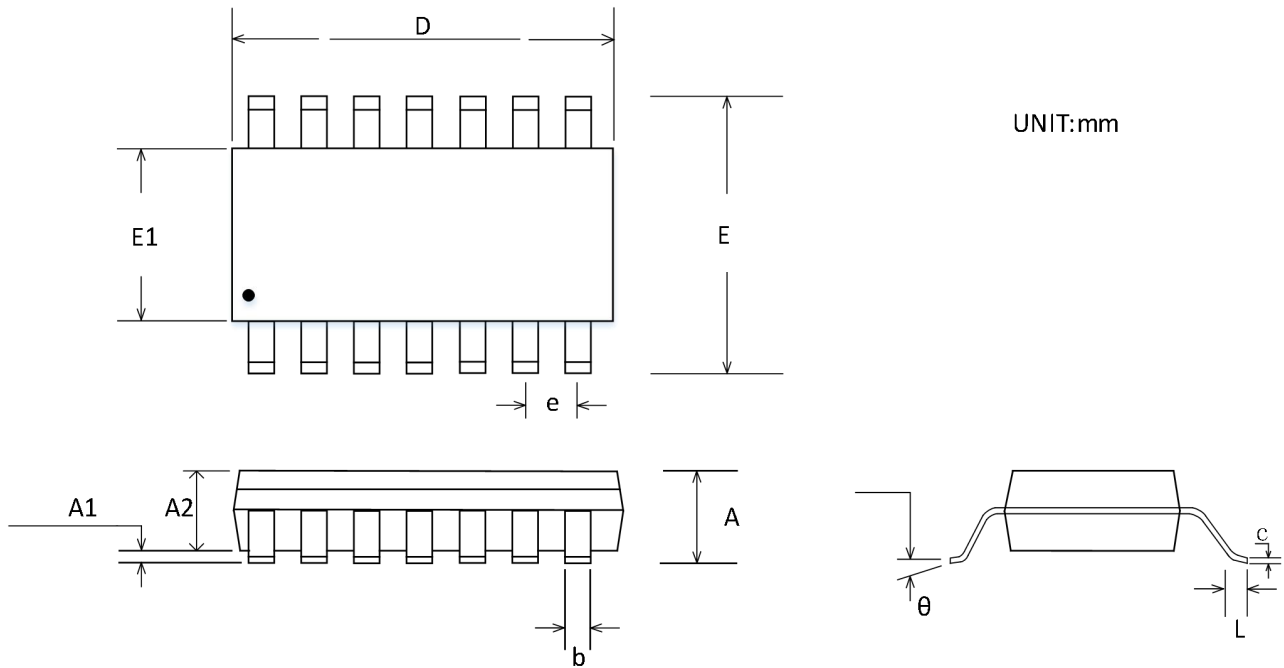

Figure 3. Output Sink Current versus Output Saturation Voltage

Outline Dimensions

SOP-14



Symbol	Dimensions In Millimeters		Dimensions Inches	
	Min	Max	Min	Max
A	1.350	1.750	0.053	0.069
A1	0.100	0.250	0.004	0.010
A2	1.350	1.550	0.053	0.061
b	0.310	0.510	0.012	0.020
c	0.100	0.250	0.004	0.010
D	8.450	8.850	0.333	0.348
E	5.800	6.200	0.228	0.244
E1	3.800	4.000	0.150	0.157
e	1.270 BSC		0.050 BSC	
L	0.400	1.270	0.016	0.050
θ	0°	8°	0°	8°

Package/Ordering Information

ORDERING	TEMP RANGE	PACKAGE	PAKEAGE	TRANSPOT
CBM2901AS14	-40°C~125°C	SOP-14	CBM2901AS	Reel, 2500
CBM2901AS14-RL	-40°C~125°C	SOP-14	CBM2901AS	Reel, 3000
CBM2901AS14-REEL	-40°C~125°C	SOP-14	CBM2901AS	Reel, 4000