

Features

- Low Offset Voltage: 65 μ V (max)
- Low input bias currents: 1 pA (max)
- Low noise: 12 nV/ \sqrt Hz
- Wide bandwidth: 8.7 MHz
- High open-loop gain: 1000 V/mV
- Unity gain stable
- Single-supply operation: 2.7 V to 5.5 V

Applications

- Photodiode amplification
- Battery-powered instrumentation
- Multipole filters
- Sensors
- Barcode scanners
- Audio

Description

The CBM8605, CBM8606, and CBM8608 are single, dual, and quad rail-to-rail input and output, single-supply amplifiers. They feature very low offset voltage, low input voltage and current noise, and gain bandwidth product characteristic of up to 8.7MHz.

The CBM8605, CBM8606, and CBM8608 are specified over the extended industrial temperature range (-40°C to $+125^{\circ}\text{C}$). The CBM8605 single is available in 5-lead SOT-23 and 5-ball WLCSP packages. The CBM8606 dual is available in an 8-lead MSOP, an 8-ball WLSCP, and a narrow SOIC surface-mounted package. The CBM8608 quad is available in a 14-lead TSSOP package and a narrow 14-lead SOIC package. The 5-ball and 8-ball WLCSP offer the smallest available footprint for any surface-mounted operational amplifier. The WLCSP, SOT-23, MSOP, and TSSOP versions are available in tape-and-reel only.

Catalog

Features.....	1
Applications.....	1
Description.....	1
Catalog.....	2
Revision log.....	3
Pin Configurations.....	4
Pin Descriptions.....	5
Absolute Maximum Ratings ⁽¹⁾	7
Electrical Characteristics.....	8
Typical Characteristics.....	11
Applications Information.....	12
Package Outline Dimensions.....	13
SOT23-5.....	13
MSOP-8.....	14
SOP-8.....	15
WLCSP-5 (CBM8605)	16
WLCSP-8 (CBM8606)	17
TSSOP-14.....	18
SOP-14.....	19
Package/Ordering Information.....	20

Revision Log

Version	Revision date	Change content	Reason for Change	Modified by	Reviewed By	Note
V1.0	2025.1.22	Update the marking information of CBM8606AMS8.	Error	WW	LYL	
V1.0	2025.1.23	Add product application information	Regular Update	WW	LYL	

Pin Configurations

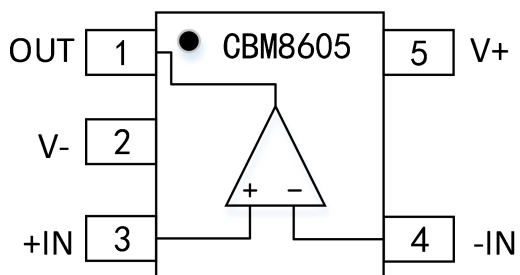

Figure1.

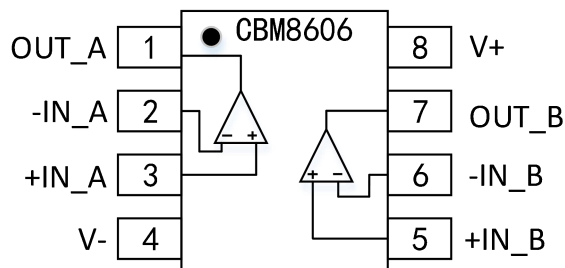
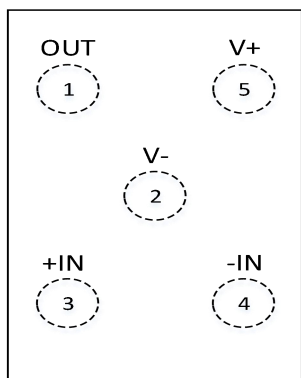

Figure2.

SOT23 Pin Configuration



CBM8605
(TOP VIEW)

Figure3.

MSOP/SOP Pin Configuration

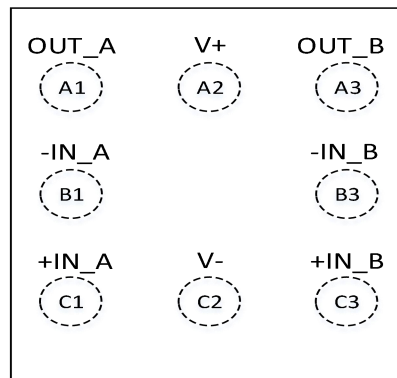

CBM8606
(TOP VIEW)

Figure4.

WLCSP Pin Configuration

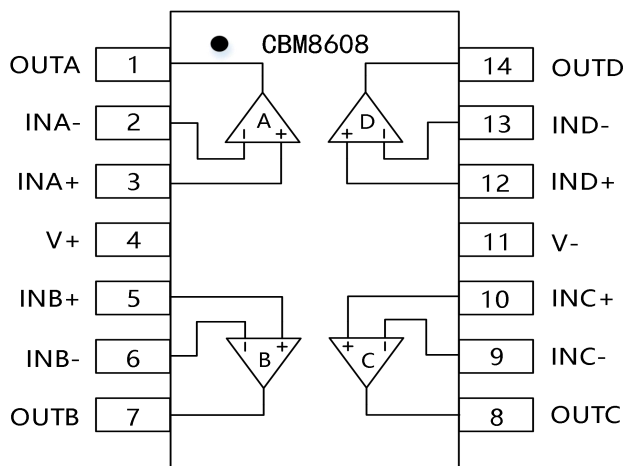

Figure5.

TSSOP/SOP Pin Configuration

Pin Descriptions

PIN_N	SYMBOL(CBM8605)	I/O	NAME AND FUNCTION
1	OUT	O	Output
2	V-	--	Negative power supply
3	+IN	I	None inverting input
4	-IN	I	inverting input
5	V+	--	Positive power supply
PIN_N	SYMBOL(CBM8606)	I/O	NAME AND FUNCTION
1	OUT_A	O	Output A
2	-IN_A	I	inverting input A
3	+IN_A	I	None inverting input A
4	V-	--	Negative power supply
5	+IN_B	I	None inverting input B
6	-IN_B	I	inverting input B
7	OUT_B	O	Output B
8	V+	--	Positive power supply
PIN_N	SYMBOL WLCSP(CBM8605)	I/O	NAME AND FUNCTION
1	OUT	O	Output
2	V-	--	Negative power supply
3	+IN	I	None inverting input
4	-IN	I	inverting input
5	V+	--	Positive power supply
PIN_N	SYMBOL WLCSP(CBM8606)	I/O	NAME AND FUNCTION
1	OUT_A	O	Output A
2	V+	--	Positive power supply
3	OUT_B	O	Output B
4	-IN_A	I	inverting input A
5	-IN_B	I	inverting input B

6	+IN_A	I	None inverting input A
7	V-	--	Negative power supply
8	+IN_B	I	None inverting input B
PIN N	SYMBOL (CBM8608)	I/O	NAME AND FUNCTION
1	OUT_A	O	Output A
2	-IN_A	I	inverting input A
3	+IN_A	I	None inverting input A
4	V+	--	Positive power supply
5	+IN_B	I	None inverting input B
6	-IN_B	I	inverting input B
7	OUT_B	O	Output B
8	OUT_C	O	Output C
9	-IN_C	I	inverting input C
10	+IN_C	I	None inverting input C
11	V-	--	Negative power supply
12	+IN_D	I	None inverting input D
13	-IN_D	I	inverting input D
14	OUT_D	O	Output D

Absolute Maximum Ratings ⁽¹⁾

- Supply Voltage: 6V
- Input Voltage : V- to V+
- Differential Input Voltage 6 V
- Storage Temperature Range All Packages :
-65°C to +150°C
- Operating Temperature Range All
Packages : -40°C to +125°C
- Junction Temperature Range All Packages :
-65°C to +150°C
- SOT23-5: 240°C/W
- MSOP-8 : 206°C/W
- SOP-8 : 157°C/W
- Lead Temperature (Soldering, 60s) : 300°C

Electrical Characteristics

($V_S = 5\text{ V}$, $V_{CM} = V_S/2$, $T_A = 25^\circ\text{C}$, unless otherwise noted.)

Table1.

PARAMETER	CONDITION	CBM8605,CBM8606,CBM8608			
		MIN	TYP	MAX	UNIT
INPUT CHARACTERISTICS					
Input Offset Voltage (V_{OS})	$V_S = 3.5\text{ V}$, $V_{CM} = 3\text{ V}$		20	65	μV
	$V_S = 2.7\text{ V}$, $V_{CM} = 0\text{ V to }2.7\text{ V}$		80	300	μV
Offset Voltage Drift ($\Delta V_{OS}/\Delta T$)			1	4.5	$\mu\text{V}/^\circ\text{C}$
Input Bias Current (I_B)			0.2	1	pA
Input Offset Current (I_{OS})			0.1	0.5	pA
Input Voltage Range		0		5	V
Common-Mode Rejection Ratio (CMRR)	$V_{CM} = 0\text{ V to }5\text{ V}$	85	100		dB
Open-Loop Voltage Gain (A_{OL})	$R_L = 2\text{K}\Omega$, $V_O = 0.5\text{ V to }4.5\text{ V}$	300	1000		dB
INPUT CAPACITANCE					
Differential (C_{DIFF})			2.6		pF
Common-Mode (C_{COM})			8.8		pF
OUTPUT CHARACTERISTICS					
Output Voltage High (V_{OH})	$I_L = 1\text{ mA}$	4.96	4.98		V
	$I_L = 10\text{ mA}$	4.7	4.79		V
Output Voltage Low (V_{OL})	$I_L = 1\text{ mA}$		20	40	mV
	$I_L = 10\text{ mA}$		170	210	mV
Output Current (I_{OUT})			± 80		mA
POWER SUPPLY					
Power Supply Rejection Ratio (PSRR)	$V_{CM} = 2.7\text{ V to }5.5\text{ V}$	75	89		dB
Supply Current/Amplifier (I_{SY})	$I_{OUT} = 0\text{ mA}$		0.8	1.2	mA
NOISE PERFORMANCE					
Peak-to-Peak Noise (e_n p-p)	$f = 0.1\text{ Hz to }10\text{ Hz}$		2.3	3.5	$\mu\text{Vp-p}$
Voltage Noise Density (e_n)	$f = 1\text{ kHz}$		8	12	$\text{nV}/\sqrt{\text{Hz}}$
Voltage Noise Density (e_n)	$f = 10\text{ kHz}$		6.5		$\text{nV}/\sqrt{\text{Hz}}$
Current Noise Density (i_n)	$f = 1\text{ kHz}$		0.01		$\text{pA}/\sqrt{\text{Hz}}$

DYNAMIC PERFORMANCE					
Slew Rate (SR)	$R_L = 2\text{ k}\Omega, C_L = 16\text{ pF}$		5		V/ μs
Gain-Bandwidth Product (GBW)			8.7		MHz
Settling Time	To 0.01%, 0 V to 2 V step, $A_V = 1$		<1		μs

($V_S = 2.7\text{V}$, $V_{CM} = V_S/2$, $T_A = 25^\circ\text{C}$, unless otherwise noted.)

Table 2.

PARAMETER	CONDITION	CBM8605,CBM8606,CBM8608			
		MIN	TYP	MAX	UNIT
INPUT CHARACTERISTICS					
Input Offset Voltage (V_{OS})	$V_S = 3.5\text{ V}, V_{CM} = 3\text{ V}$		20	65	μV
	$V_S = 2.7\text{ V}, V_{CM} = 0\text{ V to }2.7\text{ V}$		80	300	μV
Offset Voltage Drift ($\Delta V_{OS}/\Delta T$)			1	4.5	$\mu\text{V}/^\circ\text{C}$
Input Bias Current (I_B)	$V_{CM} = V_S/2$		0.2	1	pA
Input Offset Current (I_{OS})			0.1	0.5	pA
Input Voltage Range		0		2.7	V
Common-Mode Rejection Ratio (CMRR)	$V_{CM} = 0\text{V to }2.7\text{V}$	70	89		dB
Open-Loop Voltage Gain (A_{OL})	$R_L=2\text{K}\Omega, V_O=0.5\text{V to }2.2\text{V}$	110	350		V/mV
INPUT CAPACITANCE					
Differential (C_{DIFF})			2.6		pF
Common-Mode (C_{COM})			8.8		pF
OUTPUT CHARACTERISTICS					
Output Voltage High (V_{OH})	$I_L = 1\text{ mA}$	2.6	2.66		V
Output Voltage Low (V_{OL})	$I_L = 1\text{ mA}$		25	40	mV
Output Current (I_{OUT})			± 30		mA
POWER SUPPLY					
Power Supply Rejection Ratio (PSRR)	$V_{CM} = 2.7\text{V to }5.5\text{V}$	75	89		dB
Supply Current/Amplifier (I_{SV})	$I_{OUT} = 0\text{ mA}$		0.8	1.4	mA
NOISE PERFORMANCE					
Peak-to-Peak Noise ($e_n, p-p$)	$f = 0.1\text{ Hz to }10\text{ Hz}$		2.3	3.5	$\mu\text{Vp-p}$
Voltage Noise Density (e_n)	$f = 1\text{ kHz}$		8	12	$\text{nV}/\sqrt{\text{Hz}}$
Voltage Noise Density (e_n)	$f = 10\text{ kHz}$		6.5		$\text{nV}/\sqrt{\text{Hz}}$
Current Noise Density (i_n)	$f = 1\text{ kHz}$		0.01		$\text{pA}/\sqrt{\text{Hz}}$

DYNAMIC PERFORMANCE					
Slew Rate (SR)	$R_L = 2\text{ k}\Omega, C_L = 16\text{ pF}$		5		V/ μ s
Gain-Bandwidth Product (GBW)			8.7		MHz
Settling Time	To 0.01%, 0 V to 1 V step, $A_V = 1$		<0.5		us

Typical Characteristics

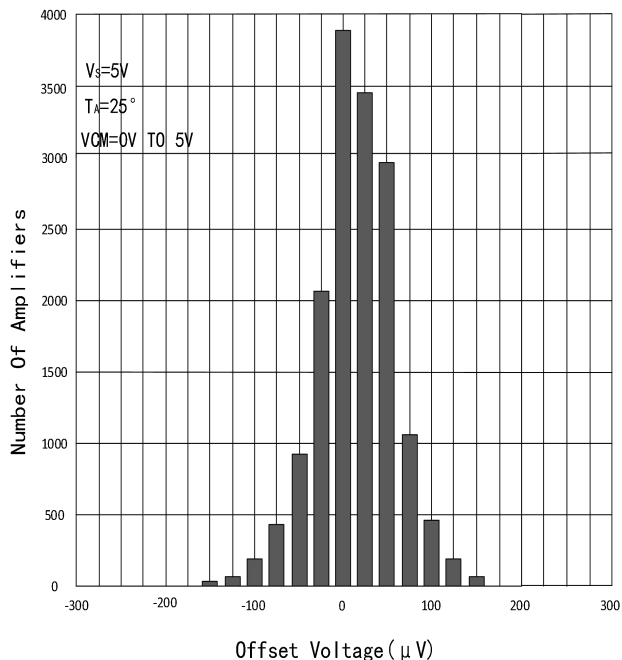

Figure6.Input Offset Voltage Distribution

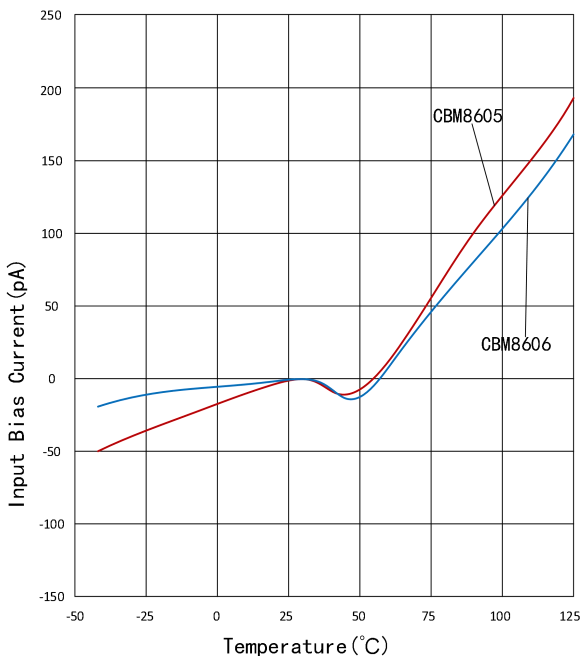

Figure7.Input Bias Current vs. Temperature

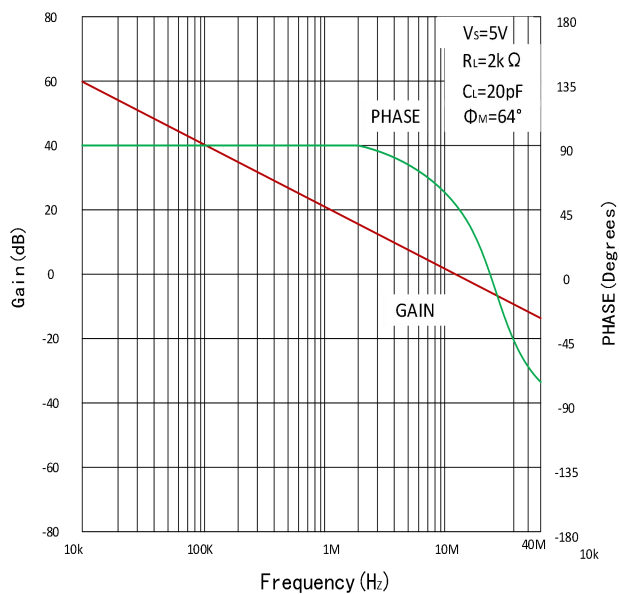

Figure8.Open-Loop Gain and Phase vs. Frequency

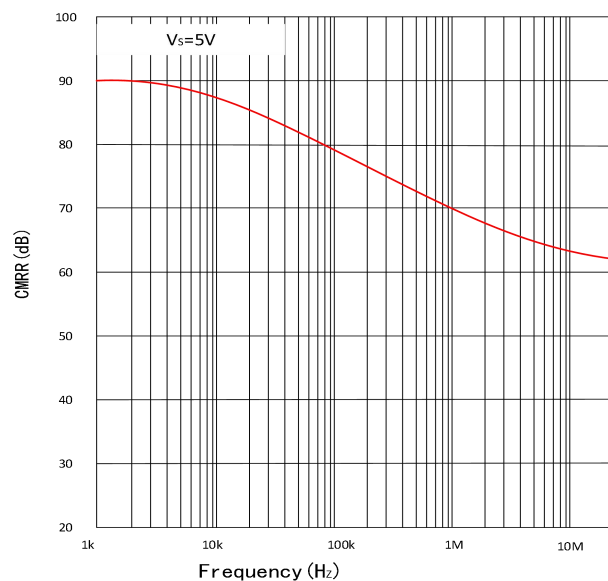

Figure9.Common-Mode Rejection Ratio (CMRR) vs. Frequency

Applications Information

Output phase reversal

Phase reversal is defined as a change in polarity at the output of the amplifier when a voltage that exceeds the maximum input common-mode voltage drives the input. Phase reversal can cause permanent damage to the amplifier; it can also cause system lockups in feedback loops. The CBM8605 does not exhibit phase reversal even for inputs exceeding the supply voltage by more than 2 V INPUT

Overvoltage protection

The CBM860x has internal protective circuitry. However, if the voltage applied at either input exceeds the supplies by more than 0.5 V, external resistors should be placed in series with the inputs. The resistor values can be determined by

$$(V_{IN}-V_S)/R_S \leq 5\text{mA}$$

The remarkable low input offset current of the CBM860x (<1 pA) allows the use of larger value resistors. With a 10 kΩ resistor at the input, the output voltage has less than 10 nV of error voltage. A 10 kΩ resistor has less than 13 nV/√Hz of thermal noise at room temperature.

Package Outline Dimensions

SOT23-5

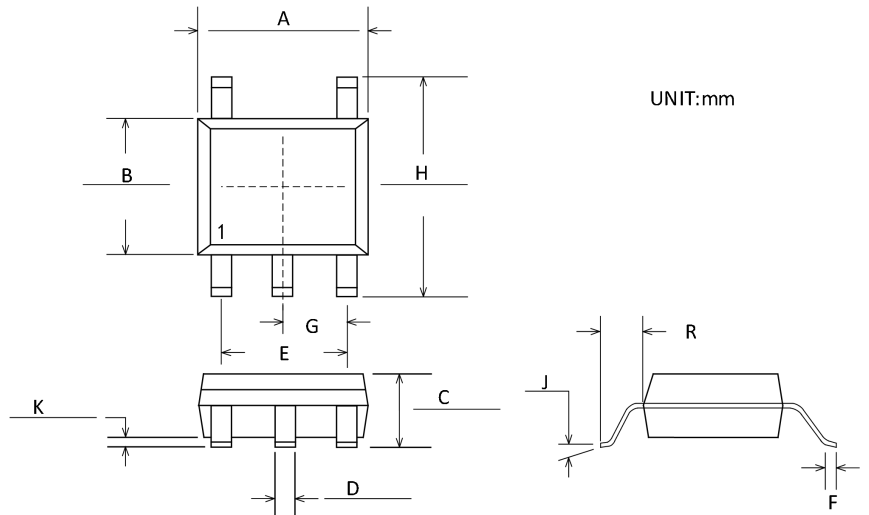

Symbol	Dimensions In Millimeters	
	Min	Max
A	2.80	3.00
B	1.50	1.70
C	0.95	1.45
D	0.35	0.50
E	1.90BSC	
F	0.35	0.55
G	0.95BSC	
H	2.60	3.00
J	0°	10°
K	0.05	0.15
R	0.60BSC	

MSOP-8

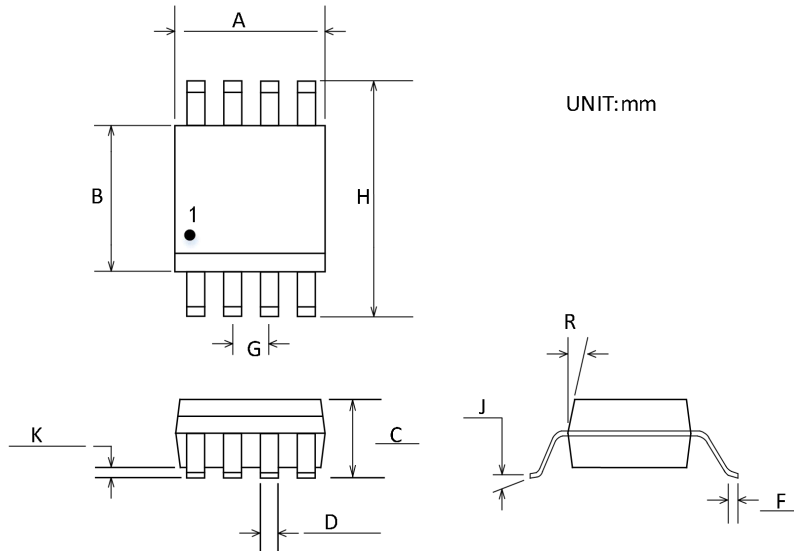

Symbol	Dimensions In Millimeters	
	Min	Max
A	2.80	3.20
B	2.80	3.20
B	1.10MAX	
D	0.25	0.40
F	0.40	0.80
G	0.65BSC	
H	4.65	5.15
J	0°	6°
K	0.05	0.15
R	15°MAX	

SOP-8

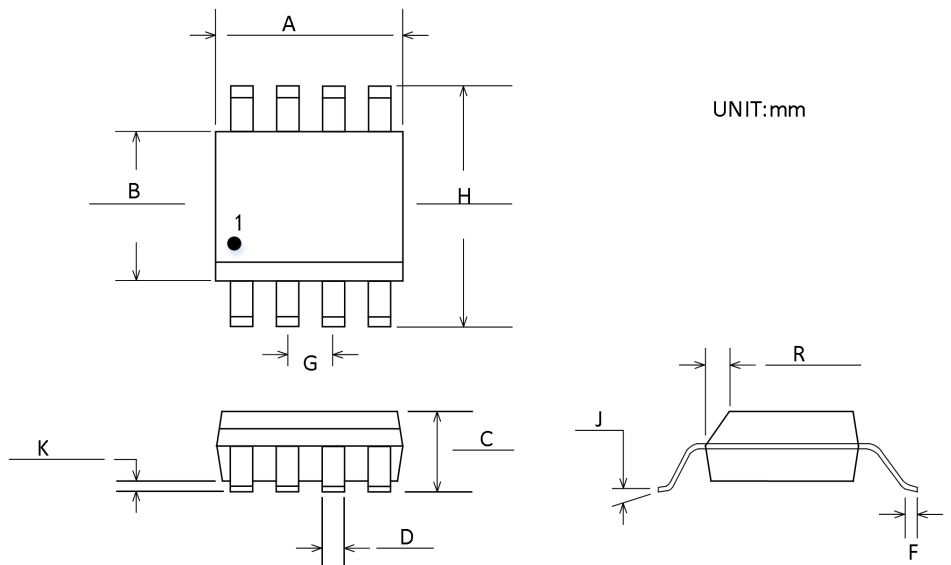

Symbol	Dimensions In Millimeters	
	Min	Max
A	4.80	5.00
B	3.80	4.00
C	1.35	1.75
D	0.31	0.51
F	0.40	1.27
G	1.27BSC	
H	5.80	6.20
J	0°	8°
K	0.10	0.25
R	0.25	0.50

WLCSP-5 (CBM8605)

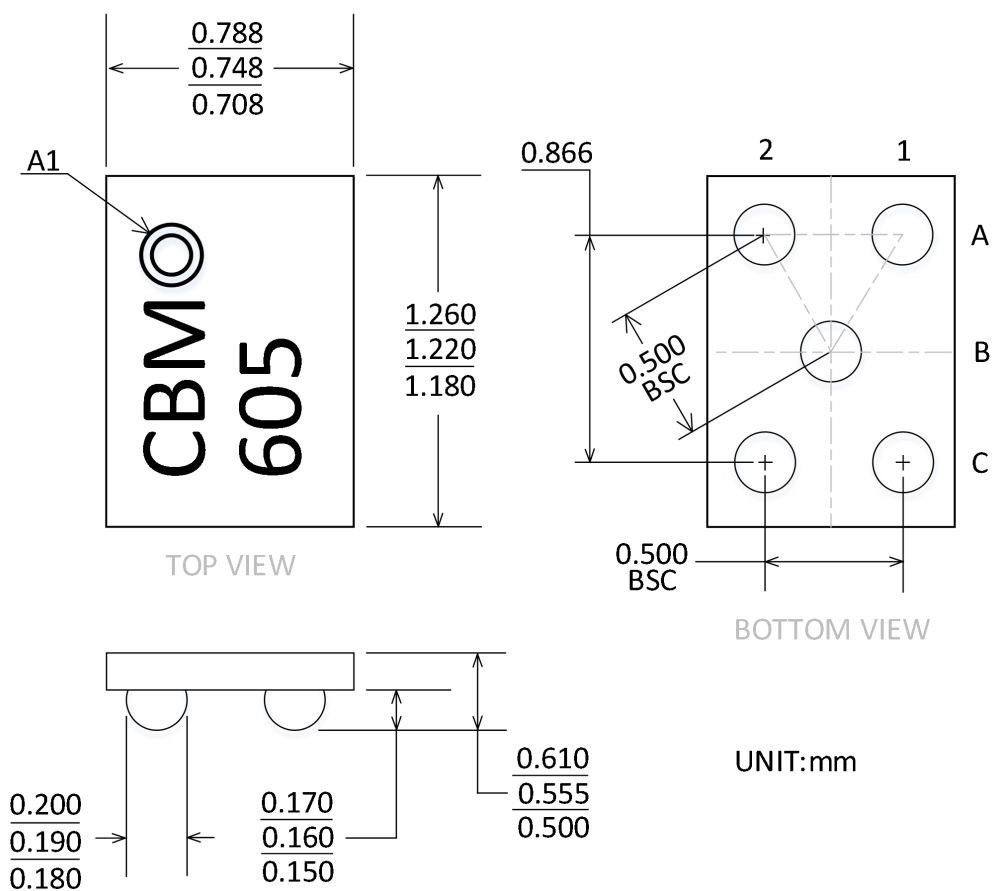

WLCSP-8 (CBM8606)

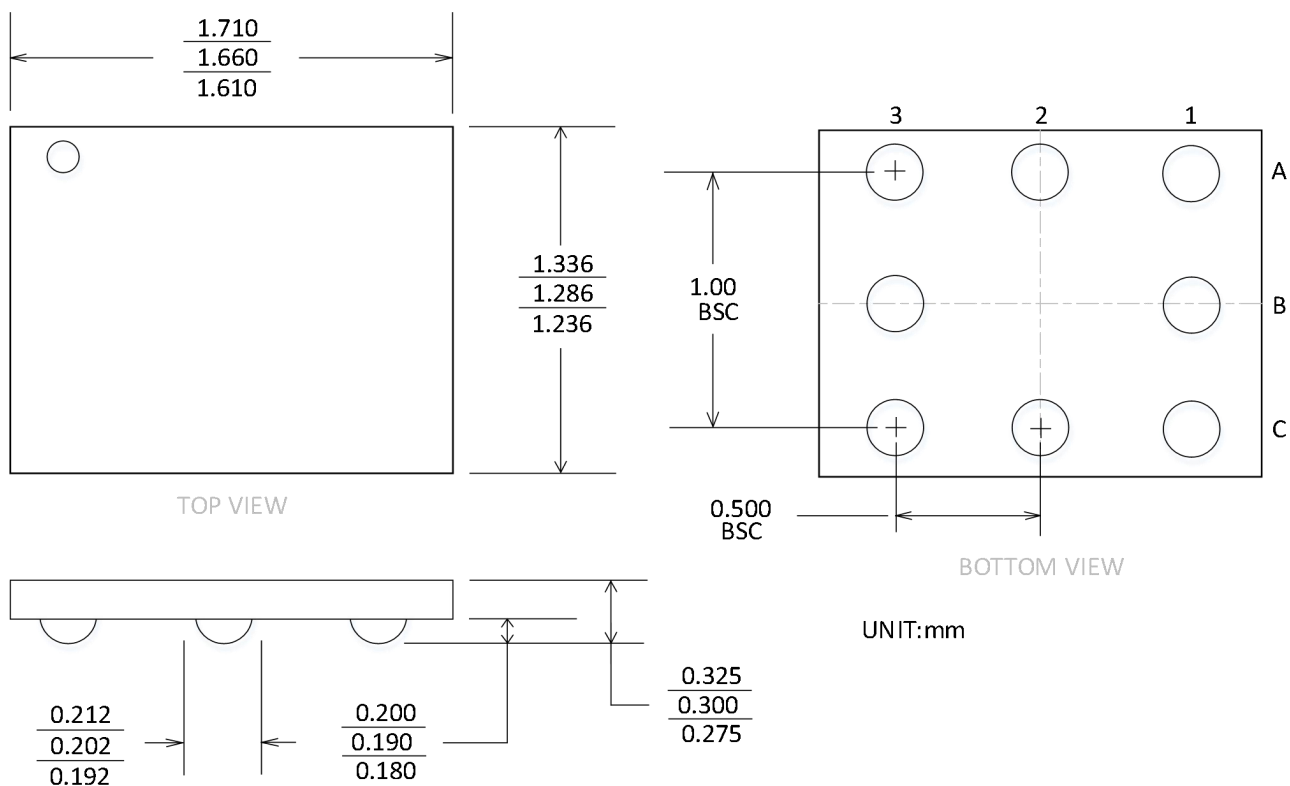

TSSOP-14

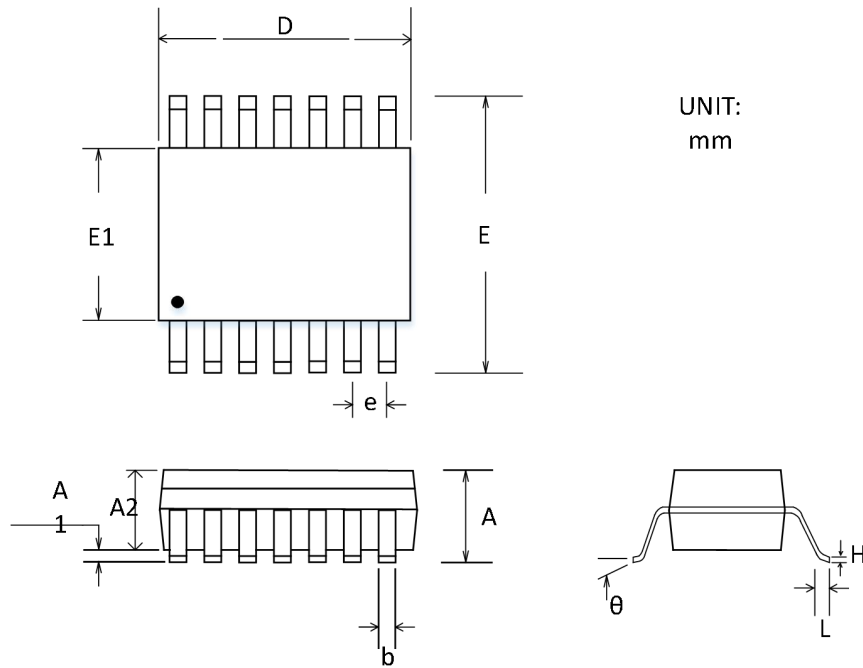

Symbol	Dimensions In Millimeters	
	Min	Max
A	1.20MAX	
A1	0.05	0.15
A2	0.80	1.05
b	0.19	0.30
D	4.90	5.10
E	6.40BSC	
E1	4.30	4.50
e	0.65BSC	
H	0.09	0.20
L	0.45	0.75
θ	0°	8°

SOP-14

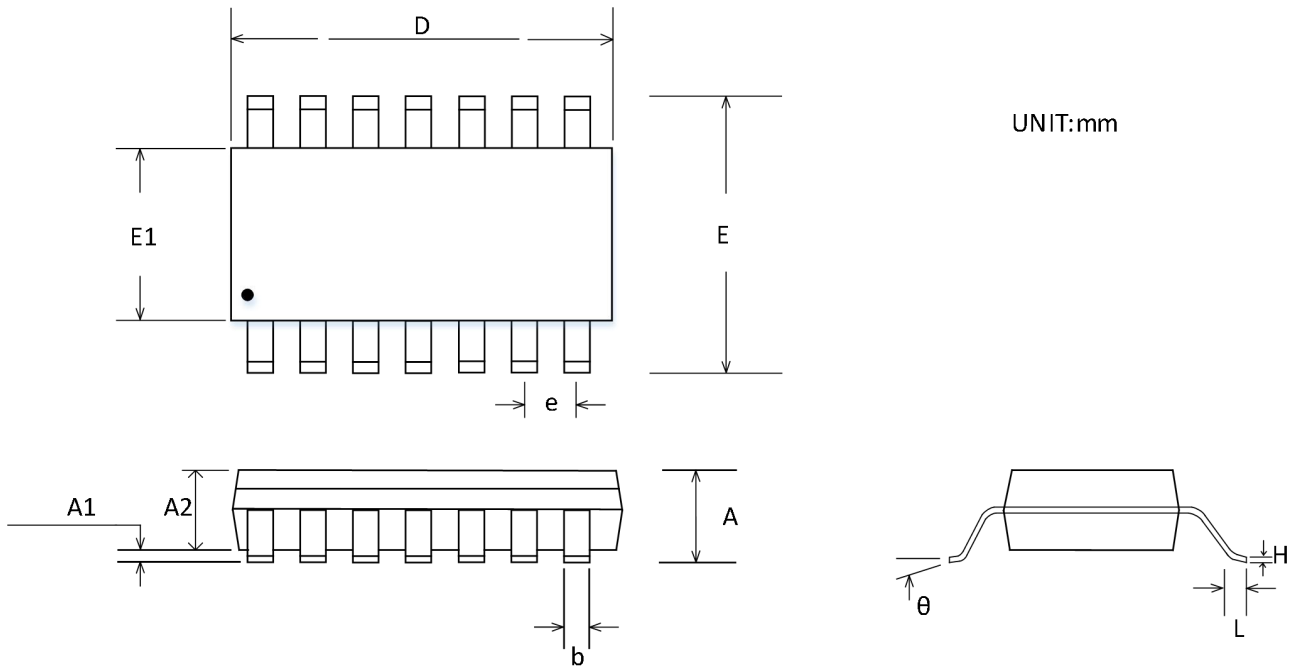

Symbol	Dimensions In Millimeters	
	Min	Max
A	1.35	1.75
A1	0.10	0.25
A2	1.25	1.50
b	0.31	0.51
D	8.55	8.75
E	5.80	6.20
E1	3.80	4.00
e	1.27BSC	
H	0.17	0.25
L	0.40	1.27
θ	0°	8°

Package/Ordering Information

PRODUCT TYPE	OPERATING TEMPERATURE	PACKAGE	PACKAGE MARKING	NUMBER OF PACKAGES
CBM8605AWS5	-40°C~125°C	WLCSP-5	AW05	Tape and Reel, 3000
CBM8605AST5	-40°C~125°C	SOT23-5	8605	Tape and Reel, 3000
CBM8606AMS8	-40°C~125°C	MSOP-8	M06	Tape and Reel, 3000
CBM8606AS8	-40°C~125°C	SOP-8	CBM8606A	Tape and Reel, 2500
CBM8606AS8-RL	-40°C~125°C	SOP-8	CBM8606A	Tape and Reel, 3000
CBM8606AS8-REEL	-40°C~125°C	SOP-8	CBM8606A	Tape and Reel, 4000
CBM8606AWS8	-40°C~125°C	WLCSP-8	AW06	Tape and Reel, 3000
CBM8608ATS14	-40°C~125°C	TSSOP-14	CBM8608AT	Tape and Reel, 2500
CBM8608ATS14-RL	-40°C~125°C	TSSOP-14	CBM8608AT	Tape and Reel, 3000
CBM8608ATS14-REEL	-40°C~125°C	TSSOP-14	CBM8608AT	Tape and Reel, 4000
CBM8608AS14	-40°C~125°C	SOP-14	CBM8608AS	Tape and Reel, 2500
CBM8608AS14-RL	-40°C~125°C	SOP-14	CBM8608AS	Tape and Reel, 3000
CBM8608AS14-REEL	-40°C~125°C	SOP-14	CBM8608AS	Tape and Reel, 4000